

131177LX

**2007-2017 JEEP JK REAR BUMPER COMBO
KIT**

**OFF CAMBER
FABRICATIONS**

by: **MBRP** INC.

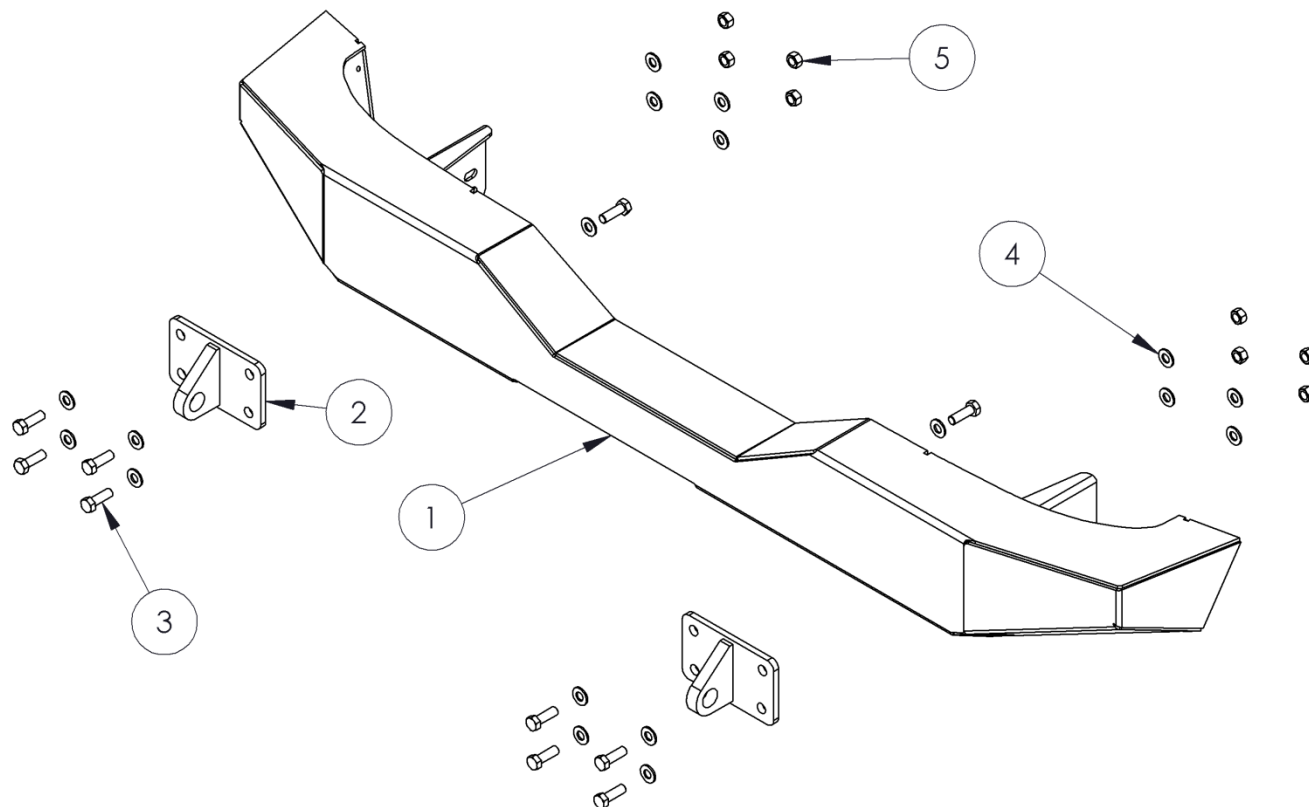

1. BUMPER
2. D RING BRACKET (2PCS)
3. 1/2" X 1.5" HEX BOLT (10 PCS)
4. 1/2" FLAT WASHER (18 PCS)
5. 1/2" HEX HUT (8 PCS)

PLEASE READ BEFORE STARTING INSTALLATION

While MBRP Inc. has made every effort to ensure that all components of this kit are of superior quality and properly packaged, it is the installer's responsibility to ensure the following before starting:

- that ALL components shown above are present.
- that ALL mating components fit together.
- that there are no damaged components.
- that the kit you have purchased is appropriate for your year and model of vehicle.
- that the kit will not interfere with any modifications previously installed or planned.
- that you have read and understand these instructions.

If you have any questions or are uncertain about any aspect of the installation of this kit on your vehicle please contact your dealer before commencing installation.

2007-2017 Jeep JK Rear Bumper Kit

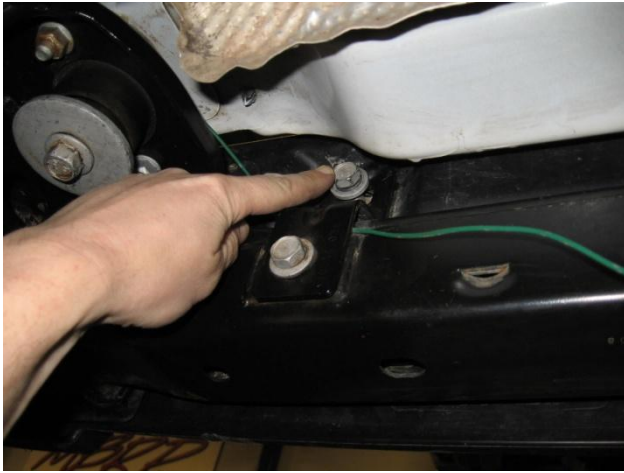

Figure 1



Figure 2

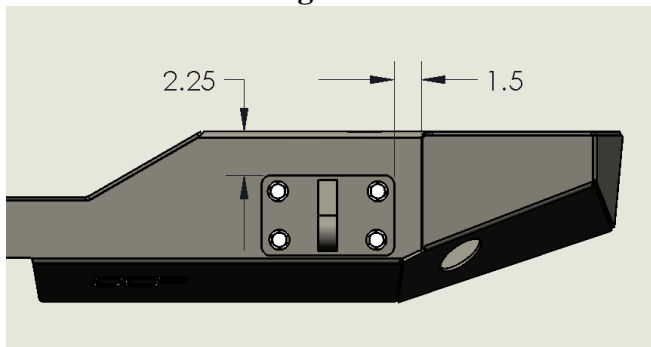

Figure 3

Removing the OEM Bumper

1. Unclip any wiring or other items that are secured to the rear bumper before beginning removal.

2. Remove the OE [Original Equipment] bumper by first removing the UPPER mounting bolts [one on each side] located on the rear frame crossmember.

Refer to Figure 1.

3. Remove the two mounting bolts located on the outside of the frame behind the rear wheels on both sides of the vehicle. Keep these bolts, they will be reused.

Refer to Figure 2.

4. Pull the bumper rearward from the vehicle and set aside.

Install D Ring Brackets

1. Using D Ring Bracket as a guide, mark and drill 8, 17/32" diameter holes.

Refer to Figure 3.

2. Install D Ring Brackets using the supplied 1/2" Hex Bolts, Flat Washers, and Hex Nuts.

3. Torque 1/2" fasteners to 60 ft./lbs.

Installation of the Full Width Rear Bumper



Figure 3



Figure 4

1. Lift the **Bumper** into position by sliding the unit onto the frame horns.
2. Align the mounting holes and reinstall the OE bolts removed in Step 3. Leave these bolts loose to allow for alignment later. **Refer to Figure 3.**
3. Install the supplied ½” **Hex Bolts**, and ½” **Washers** through the frame crossmember brackets and thread into the **Bumper**. **Refer to Figure 4.**
4. Align the Bumper and tighten all bolts.

Congratulations! You are finished. We are sure that you will enjoy this **Off Camber Fabrications** product by **MBRP Inc.**

