

183100
REAR BUMPER
2016 AND UP TOYOTA TACOMA WITH
TOW PACKAGE

OFF CAMBER
FABRICATIONS

by: **MBRP** INC.

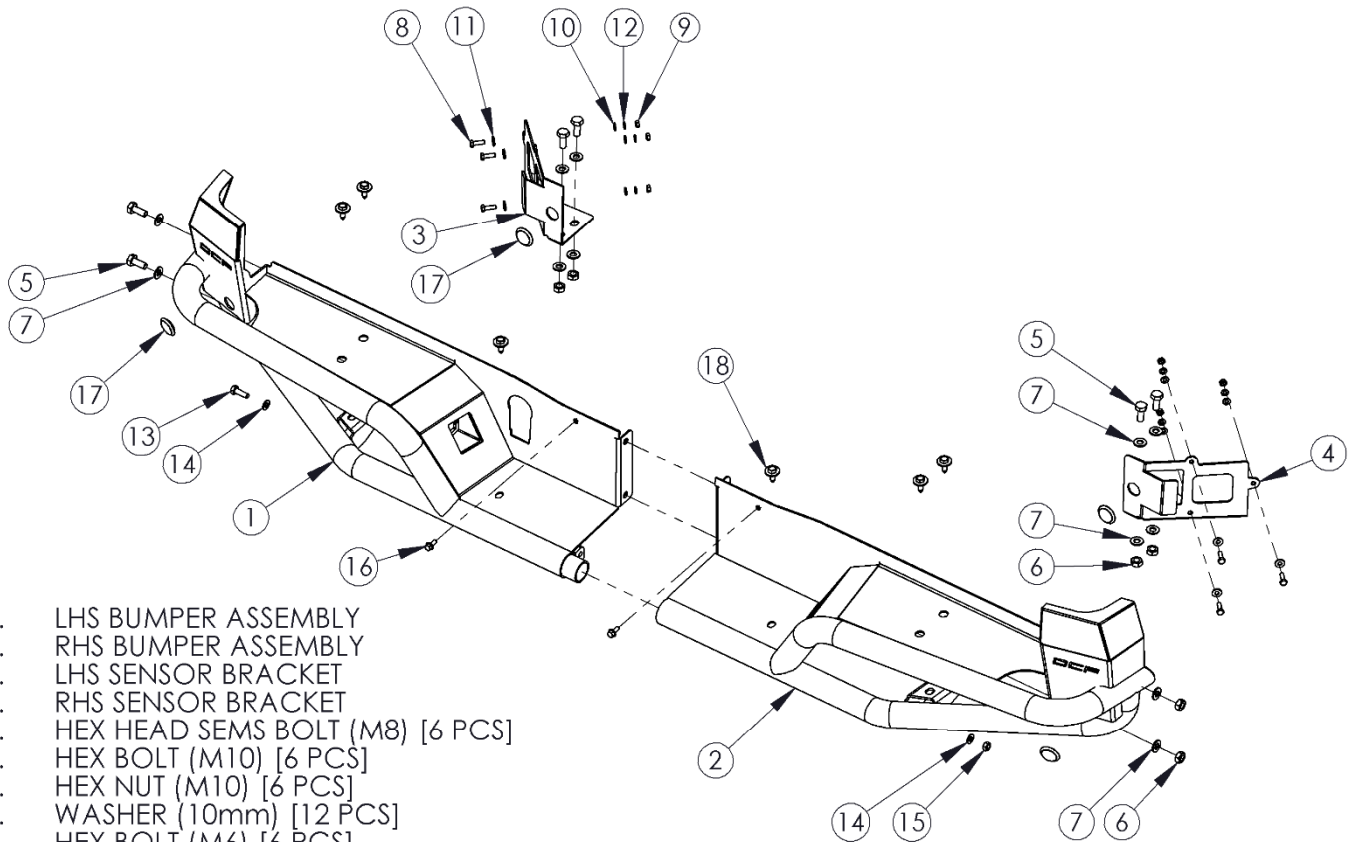

1. LHS BUMPER ASSEMBLY
2. RHS BUMPER ASSEMBLY
3. LHS SENSOR BRACKET
4. RHS SENSOR BRACKET
5. HEX HEAD SEMS BOLT (M8) [6 PCS]
6. HEX BOLT (M10) [6 PCS]
7. HEX NUT (M10) [6 PCS]
8. WASHER (10mm) [12 PCS]
9. HEX BOLT (M6) [6 PCS]
10. HEX NUT (M6) [6 PCS]
11. WASHER (6mm) [6 PCS]
12. WASHER (1/4") [6 PCS]
13. LOCK WASHER (6mm) [6 PCS]
14. HEX BOLT (M8)
15. WASHER (8mm) [2 PCS]
16. HEX NUT (M8)
17. SCREW (M6) [2 PCS]
18. HOLE PLUG

PLEASE READ BEFORE STARTING INSTALLATION

While MBRP Inc. has made every effort to ensure that all components of this kit are of superior quality and properly packaged, it is the installer's responsibility to ensure the following before starting:

- that ALL components shown above are present.
- that ALL mating components fit together.
- that there are no damaged components.
- that the kit you have purchased is appropriate for your year and model of vehicle.
- that the kit will not interfere with any modifications previously installed or planned.
- that you have read and understand these instructions.

If you have any questions or are uncertain about any aspect of the installation of this kit on your vehicle please contact your dealer before commencing installation.

REMOVAL OF STOCK REAR BUMPER

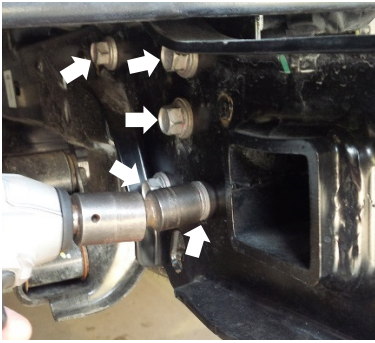

Figure 1

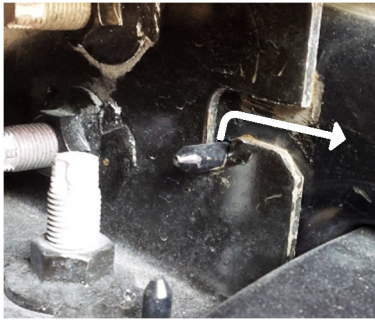

Figure 2



Figure 3

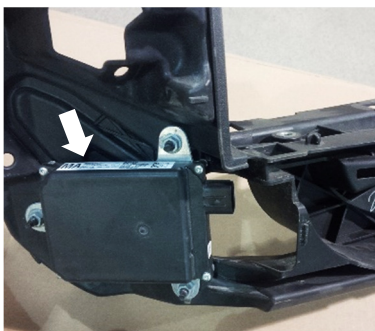

Figure 4



Figure 5

1. Remove the flange bolts (5 each side) securing the hitch structure to the vehicle frame rails. **Refer to Figure 1.**
2. Disconnect the main wiring harness and the trailer wiring connection from the rear bumper.
3. Remove the rear bumper from the vehicle by working the locating pins on the structure mounting brackets out through the positioning slots of the frame rails. **Refer to Figure 2.**
4. Disassemble the components of the bumper. Remove the step pad by disengaging the snaps (**Refer to Figure 3**), then unbolt the steel frame and corner assemblies from the hitch structure.
5. Remove the wiring harness from the lights and any sensors. It will be reused.
6. Remove the towing electrical socket from the stock bumper. It will be reused.
7. Remove the license plate light lenses by pushing in the side tabs (take care not to break the tabs). The lights and lenses will be reused on the new bumper.
8. If the stock bumper is equipped with blind-spot sensors or sonar parking sensors, remove the corner claddings to access and remove them (they will be reused)*. **Refer to Figure 4.**

** Please note that, MBRP cannot guarantee the proper function of the sensors once removed from the OEM bumper and reinstalled onto the OCF bumper. While the sensors have been shown to work properly with the OCF bumper, issues or malfunctions can arise due to sensor calibration and environmental conditions, particularly with the blind-spot monitor (BSM) units. Also, removal of OEM sensors from the stock bumper may void the OEM warranty.*

INSTALLATION OF THE OCF BUMPER

1. Reinstall the hitch structure to the vehicle frame rails, replacing the previously removed stock flange bolts (10). **Refer to Figure 5.**
2. Assemble the **LHS Bumper Assembly** to the **RHS Bumper Assembly** using two (2) **M10 Hex Bolts** and **M10 Nuts** with four (4) **10mm Washers** in the connection flange holes, and the **M8 Hex Bolt**, **M8 Hex Nut**, and two (2) **8mm Washers** in the front tab holes. Tighten the hardware. **Refer to Figure 6.**

OFF CAMBER FABRICATIONS

by: **MBFP**
INC.



Figure 6



Figure 7

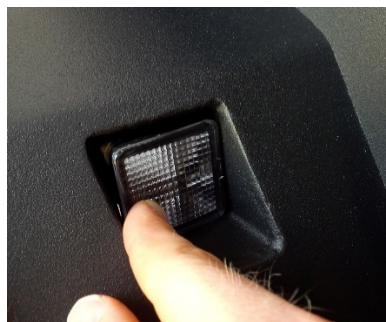

Figure 8



Figure 9



Figure 10

3. Place the **assembled bumper** onto the hitch structure and align the holes in the top plate to the threaded holes of the structure, then thread the **Hex Head SEMS Bolts** into each hole. **Refer to Figure 7.**
4. Position the bumper in the desired position and then tighten the **Hex Head SEMS Bolts**.
5. Insert the license plate light assembly into the designated cut-outs on the bumper (note that the alignment tab and slot need to line up). **Refer to Figure 8.**
6. Insert the towing electrical socket into the provided cut-out. Connect the towing wiring harness to the socket.
7. Reconnect the wiring harness that was previously removed from the stock bumper assembly, and connect the licence plate lights.

If installing the stock blind-spot or parking sensors, proceed to Step 8. If the truck is not equipped with blind-spot sensors and/or sonar parking sensors, or you do not wish to reuse them, installation of the **LHS and RHS Sensor Brackets** is not required; proceed to Step 14.
8. Place the **LHS Sensor Bracket** on top of the lower flange on the hitch structure, and install two (2) **M10 Hex Bolts** with **10mm Washers** (4) and **M10 Hex Nuts** (2) through the holes of the **LHS Bumper Assembly** bracket. Tighten the fasteners. **Refer to Figure 9.**
9. Run the blind-spot sensor wire lead through the hole located on the bend of the **LHS Sensor Bracket**, and connect it to the blind-spot sensor. **Refer to Figure 10.**
10. Attach the blind spot sensor to the **LHS Sensor Bracket** using the **M6 Hex Bolts** (3), **1/4" Washers** (3), **6mm Washers** (3), **6mm Lock Washers** (3), and **M6 Nuts** (3). **Refer to Figure 11.**
11. Install one of the sonar parking sensors into the hole on the **LHS Sensor Bracket**, and connect the appropriate wire lead from the wiring harness. **Refer to Figure 12.** Install the other sensor into the hole at the bottom of the corner plate and connect the wire lead to it. If the parking sensors are not being used, install the provided **Hole Plugs** in each hole. **Refer to Figure 13.**
12. Repeat Steps 8-11 for the **RHS Sensor Bracket** and sensors.

Note: The sensors have different horizontal and vertical sensing fields. If a sensor is falsely triggering on the bumper, try rotating it to a different position.

OFF CAMBER FABRICATIONS

by: **MBRP** Inc.



Figure 11



Figure 12



Figure 13

13. Finally, use the **M6 Screws** to mount your license plate.

Note: *The sensors have changed from their original location and they may not be triggered in exactly the same circumstances as before. Take time to learn and adjust to the new operating ranges.*

14. Install two (2) **M10 Hex Bolts** with **10mm Washers** (4) and **M10 Hex Nuts** (2) through the holes of the lower flange on the hitch structure and the **LHS Bumper Assembly** bracket. Repeat this step for the **RHS Bumper Assembly**, and tighten the fasteners. **Refer to Figure 9.**

15. Insert the supplied **Hole Plugs** into the unused holes at the bottom of each end plate. **Refer to Figure 13.**

16. Finally, use the **M6 Screws** to mount your license plate.



Congratulations! You're finished! We are sure that you will enjoy this **Off Camber Fabrications** product by **MBRP Inc.**