

# AT-9215PT

EXHAUST ASSEMBLY, SLIP-ON, CENTER EXIT  
2021-UP CAN-AM COMMANDER 1000  
2022-UP CAN-AM MAVERICK SPORT 1000R

# MBRP

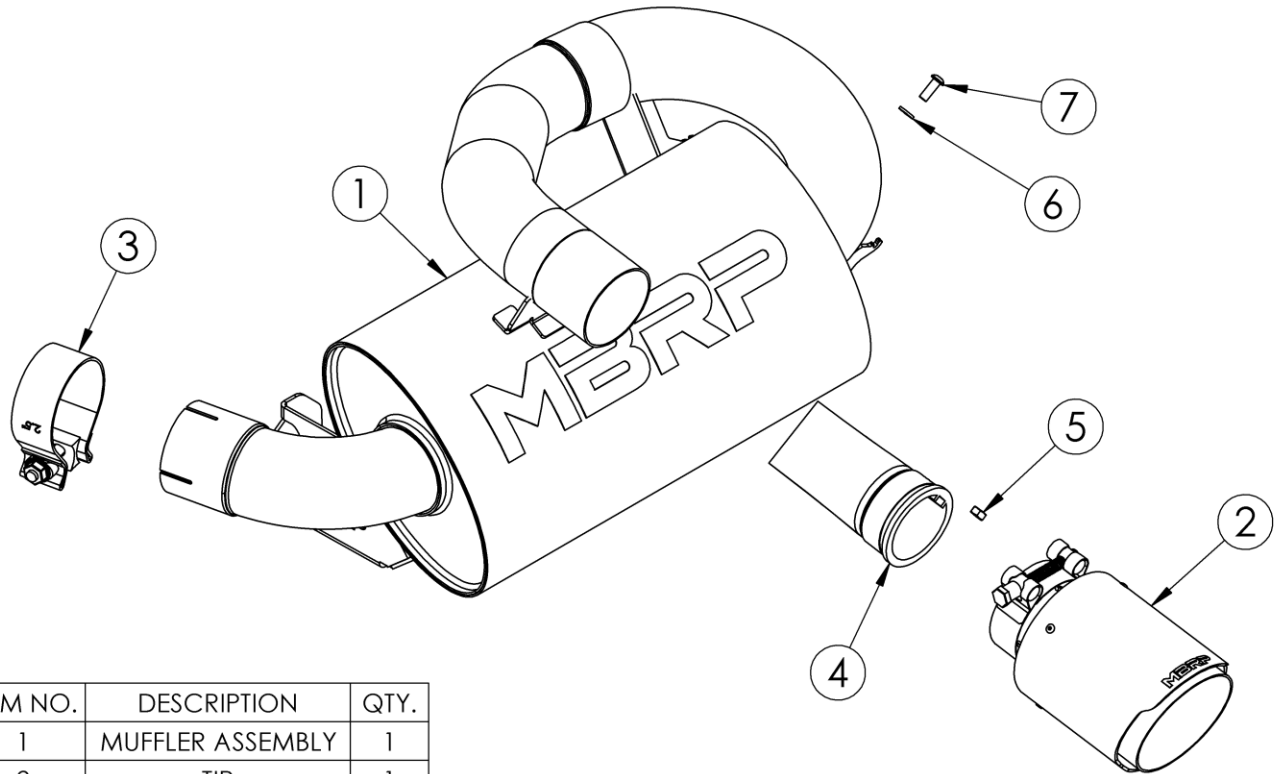

ITEM NO.	DESCRIPTION	QTY.
1	MUFFLER ASSEMBLY	1
2	TIP	1
3	2.5" CLAMP	1
4	SPARK ARRESTOR	1
5	NUT	1
6	LOCK WASHER	1
7	SCREW	1

ITEMS 4, 5, 6, & 7 ARE PRE-ASSEMBLED TO MUFFLER

## PLEASE READ BEFORE STARTING INSTALLATION

While MBRP Ltd. has made every effort to ensure that all components of this system are of superior quality and properly packaged, it is the installer's responsibility to ensure the following before removal of the factory exhaust:

- that ALL components shown above are present.
- that ALL mating components fit together.
- that there are no damaged components.
- that the system you have purchased is appropriate for your vehicle year, model and configuration.
- that the system will not interfere with any modifications previously installed or planned.
- that you have read and understand these instructions.

If you have any questions or are uncertain about any aspect of the installation of this system to your vehicle please contact your dealer before commencing installation.

# MBRP

## Removal of Stock Exhaust:



Figure 1

1. Loosen the band clamp and remove the two (2) bolts securing the muffler inlet heat shield, then remove the shield. **Refer to Figure 1.**
2. Loosen the clamp securing the muffler inlet to the front pipe.
3. Remove the four (4) springs securing the muffler to the vehicle. Keep the springs as they will be reused to mount the new system.
4. Lift the outlet side of the muffler to free the bottom locating post, then work the stock muffler straight back to free the inlet from the front pipe. Remove the muffler.

## Installation of MBRP Exhaust:



Figure 2

1. Place the **2.5" Clamp** onto the **Muffler** inlet, then put the **Muffler** into position and slide the inlet onto the front pipe. Rotate the down to insert the locating post into the rubber mount.
2. Once the muffler is aligned, reinstall the stock springs (4) to the **Muffler** tabs. **Refer to Figure 2.**
3. In order to install the **Tip**, the **Screw** (and **Lock Washer**) securing the **Spark Arrestor** inside the outlet must be removed temporarily. Be careful not to lose the **Nut** on the inside of the **Spark Arrestor**, as it may fall out when the **Screw** is removed.



Figure 3

With the **Screw** removed, slide the **Tip** over the **Muffler** outlet and line up the hole on the tip inlet with the screw hole in the **Muffler** outlet. Holding the **Nut** and **Spark Arrestor** in place (re-align the **Nut** with the hole if necessary), reinstall the **Washer** and **Screw**. **Refer to Figure 3.**

4. Tighten the clamp to fully secure the **Tip**. **Refer to Figure 4.**
5. Finally, ensure that the **Muffler** assembly is properly aligned, and then tighten the **2.5" Clamp** on the muffler inlet.

It is recommended that the hardware be retightened after the first ride and checked periodically thereafter, tightening if necessary. In order to maintain optimal performance, the spark arrestor screen should be cleaned after every 30-35 hours of use.

**NOTE:** For Commander models, DO NOT leave the engine running with the cargo bed in the dump position.



Figure 4



**Congratulations!** You are ready to begin experiencing the improved performance and driving excitement of your **MBRP** exhaust upgrade. We know you will enjoy your purchase.