

C1652ALNB / C1652409NB
2011 FORD SUPER DUTY 6.7L POWERSTROKE
4" COMPETITION PIPES

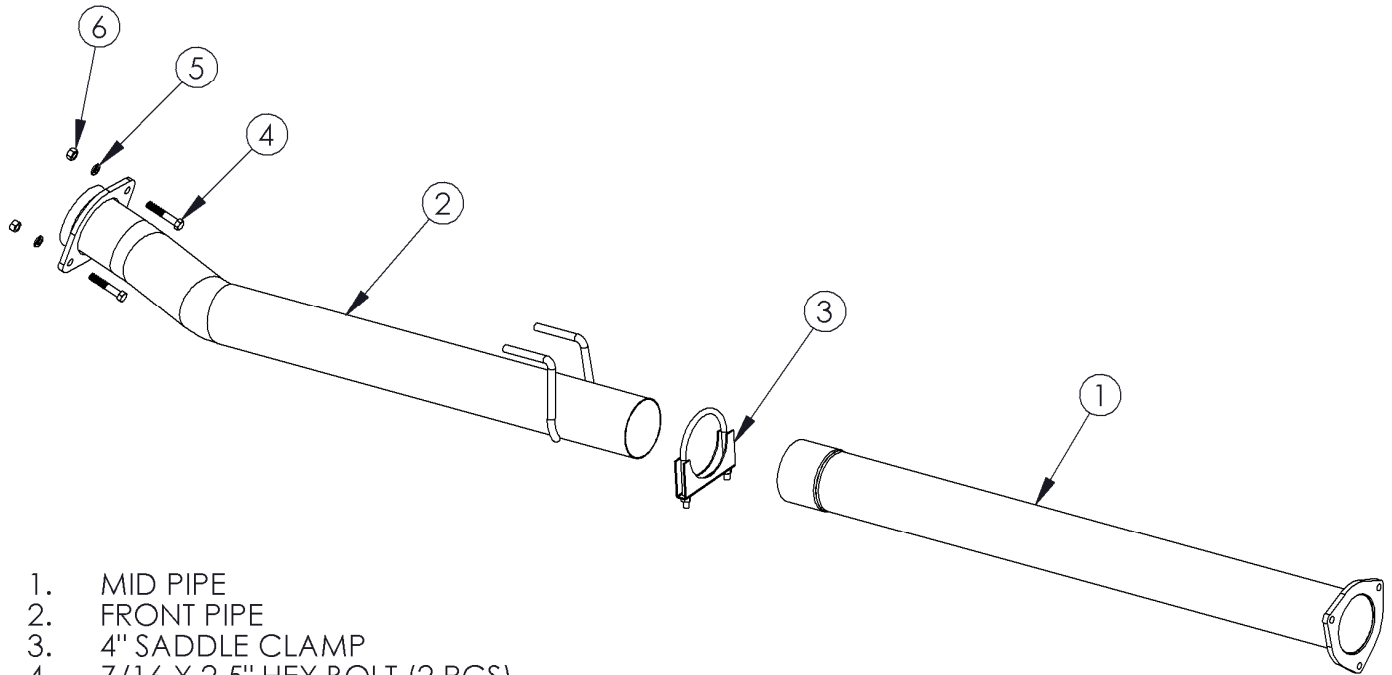

1. MID PIPE
2. FRONT PIPE
3. 4" SADDLE CLAMP
4. 7/16 X 2.5" HEX BOLT (2 PCS)
5. 7/16" LOCK WASHER (2 PCS)
6. 7/16" HEX NUT (2 PCS)

FOR RACE/COMPETITION USE ONLY!

Installation of this product for highway or recreational use vehicles is prohibited by Federal law. This product's use is restricted to organized, amateur and professional racing events, limited to closed-course racing and open-course racing that is formally sanctioned by a recognized racing organization.

This system requires an aftermarket electronic programmer to work with the vehicle.

PLEASE READ BEFORE STARTING INSTALLATION

While MBRP Inc. has made every effort to ensure that all components of this system are of superior quality and properly packaged it is the installer's responsibility to ensure the following before removal of the factory exhaust:

- that ALL components shown above are present.
- that ALL mating components fit together.
- that there are no damaged components.
- that the system you have purchased is appropriate for your vehicle year, model and configuration.
- that the system will not interfere with any modifications previously installed or planned.
- that you have read and understand these instructions.

If you have any questions or are uncertain about any aspect of the installation of this system to your vehicle please contact your dealer before commencing installation.

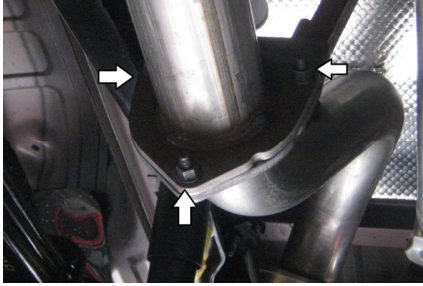

Figure 1

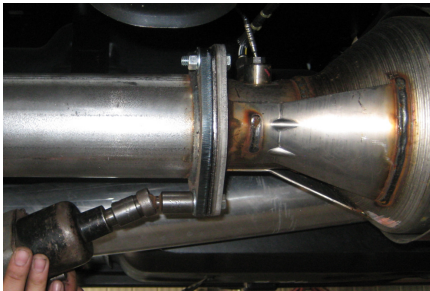

Figure 2



Figure 3



Figure 4



Figure 5

Removal of Stock System:

1. Apply some penetrating lubricant liberally to all exhaust fasteners, hangers and rubber insulators.
2. Loosen the three (3) nuts securing the extension pipe flange to the over-axle pipe. **Refer to Figure 1.**
3. Remove the factory over-axle/tail pipe.
4. Loosen the three (3) nuts securing the extension pipe to the flange directly behind the exhaust filter and remove the extension pipe. **Refer to Figure 2.**
5. Disconnect all exhaust sensors at their connection points to the vehicle.
6. Remove the flange connecting the CAT/DPF section of the exhaust to the downpipe.
7. Remove the exhaust hangers from the isolator mounts and remove the CAT/DPF section from the vehicle (this step will require two people, as the stock pipe is heavy).

Installation of MBRP Inc. Competition Pipe:

1. Install the **Front Pipe** by inserting the hanger into the factory isolator mount and connecting the flange to the downpipe using the **7/16" Hardware** provided. **Refer to Figure 3.**
2. Install the **Mid Pipe** onto the **Front Pipe** using the **4" Saddle Clamp** provided. Do not fully tighten the clamp yet. **Refer to Figure 4.**
3. Re-install the stock extension pipe to the flange of the **Mid Pipe** using the original hardware. Then re-install the stock tail pipe. **Refer to Figure 5.**
4. Align the exhaust as needed and tighten all clamps.

Congratulations! MBRP Competition Exhaust Systems is proud to be a part of your racing and competition success. We know you will enjoy your purchase.