

C6258409

2008-2010 FORD SUPER-DUTY 6.4L POWERSTROKE
DOWN-PIPE BACK 5" SINGLE EXHAUST
CREW CAB, SUPER CAB LONG BOX

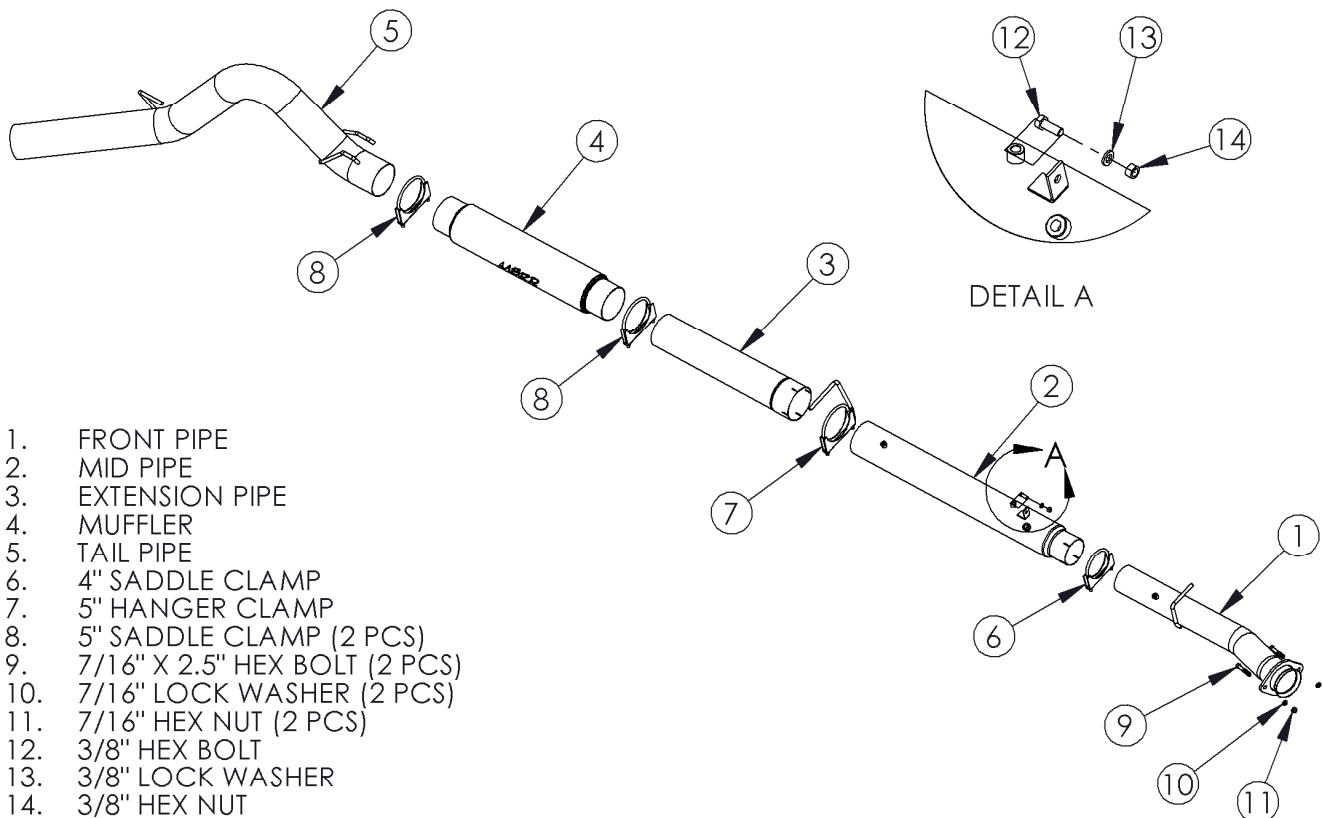

FOR RACE/COMPETITION USE ONLY!

Installation of this product for highway or recreational use vehicles is prohibited by Federal law. This product's use is restricted to organized, amateur and professional racing events, limited to closed-course racing and open-course racing that is formally sanctioned by a recognized racing organization.

This system requires an aftermarket electronic programmer to work with the vehicle.

PLEASE READ BEFORE STARTING INSTALLATION

While MBRP Inc. has made every effort to ensure that all components of this system are of superior quality and properly packaged it is the installer's responsibility to ensure the following before removal of the factory exhaust:

- that ALL components shown above are present.
- that ALL mating components fit together.
- that there are no damaged components.
- that the system you have purchased is appropriate for your vehicle year, model and configuration.
- that the system will not interfere with any modifications previously installed or planned.
- that you have read and understand these instructions.

If you have any questions or are uncertain about any aspect of the installation of this system to your vehicle please contact your dealer before commencing installation.

Removal of Stock System:



Figure 1

1. Apply penetrating lubricant liberally to all exhaust fasteners, hangers and rubber isolators.
2. Loosen the nut on the band clamp located behind the particulate filter using a 15mm wrench or socket. **Refer to Figure 1.**
3. Remove the tail pipe from the particulate filter.
4. Disconnect all exhaust sensors at their connection points to the vehicle.
5. Remove the flange connecting the catalytic converter and diesel particulate filter section of the exhaust to the down pipe. **Refer to Figure 2.**
6. Remove the exhaust hangers from the isolator mounts and remove the catalytic converter and diesel particulate filter section from the vehicle (this step will require two people, as the stock pipe is heavy).



Figure 2

Installation of MBRP Competition Exhaust:

1. Install the **Front Pipe** by inserting the hanger into the factory isolator mount and connecting the flange to the down pipe using the **7/16" Hardware** provided. **Refer to Figure 3.**
2. Install the **Mid Pipe** onto the **Front Pipe** using the **4" Clamp** provided. Do not fully tighten the clamp yet. **Refer to Figure 4.**
3. The **Extension Pipe** is pre-cut for the 172.4" (crew cab, long box) wheelbase. If installing on a 158" or 156.2" wheelbase vehicle, cut the **Extension Pipe** to the appropriate length. **Refer to Figure 5.**

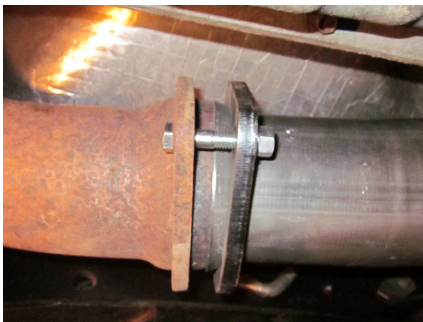

Figure 3

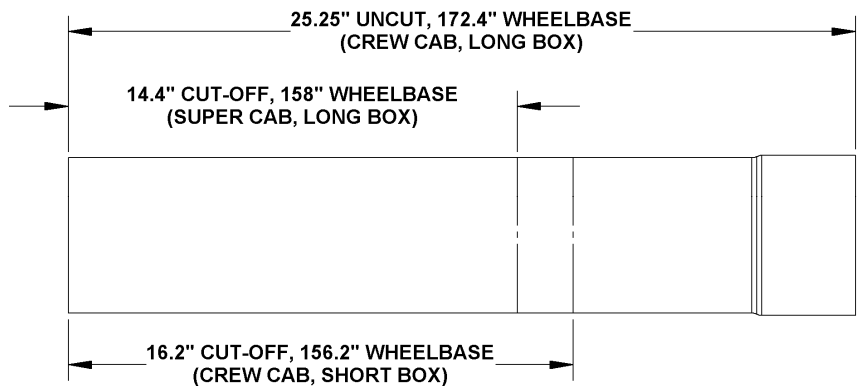

Figure 5



Figure 4

4. Place the **Hanger Clamp** into the rubber isolator and onto the free end of the **Mid Pipe** and install the **Extension Pipe** onto the **Mid Pipe**. Do not fully tighten the hanger clamp yet. **Refer to Figure 6.**



Figure 6

5. Install the **Muffler** onto the **Extension Pipe** using a **5" Clamp**.
Refer to Figure 7.

6. Insert the **Tail Pipe** hangers into the rearmost rubber isolators and install the tail pipe into the muffler using a **5" Clamp** to secure it. Do not fully tighten the clamp yet. **Refer to Figure 8.**

7. Align the exhaust as needed and tighten all clamps.

8. Re-install the sensors in the provided ports. Attach the pressure sensor bracket using the **3/8" Hardware** provided.

Congratulations! MBRP Competition Exhaust Systems is proud to be a part of your racing and competition success. We know you will enjoy your purchase.

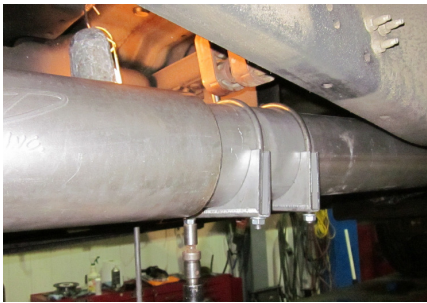

Figure 7



Figure 8