

C6262P

4" COMPETITION EXHAUST
2011 FORD SUPER DUTY 6.7L POWERSTROKE

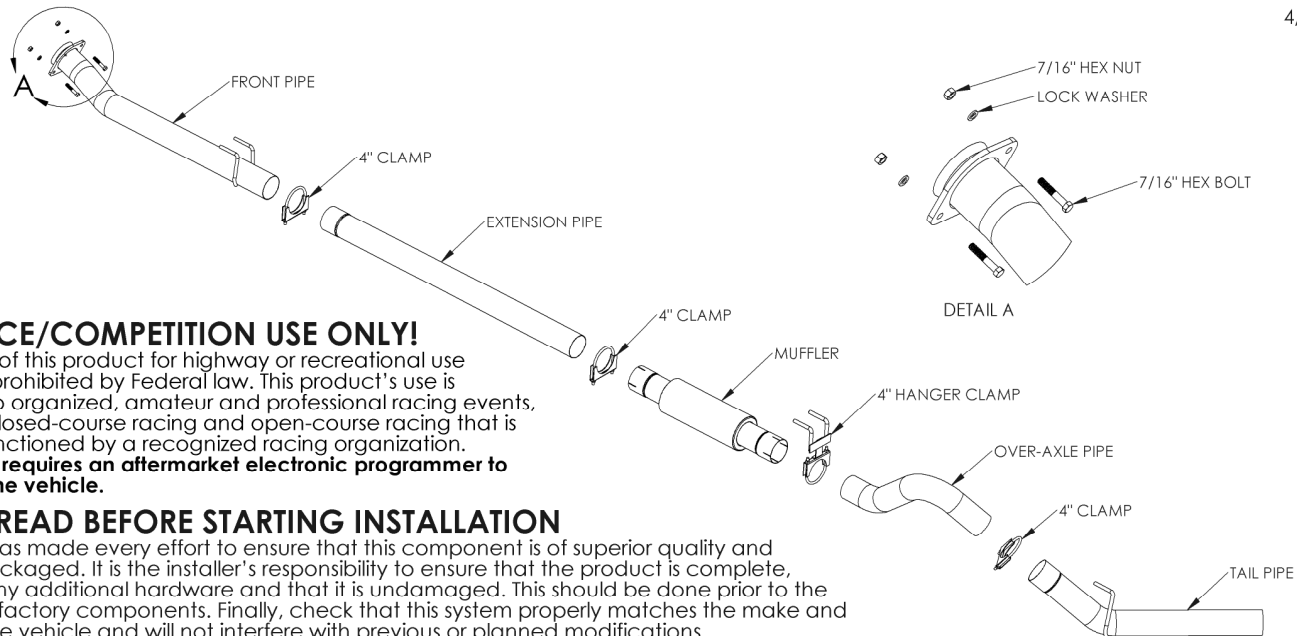

4/20/2011



FOR RACE/COMPETITION USE ONLY!

Installation of this product for highway or recreational use vehicles is prohibited by Federal law. This product's use is restricted to organized, amateur and professional racing events, limited to closed-course racing and open-course racing that is formally sanctioned by a recognized racing organization. **This system requires an aftermarket electronic programmer to work with the vehicle.**

PLEASE READ BEFORE STARTING INSTALLATION

MBRP Inc. has made every effort to ensure that this component is of superior quality and properly packaged. It is the installer's responsibility to ensure that the product is complete, including any additional hardware and that it is undamaged. This should be done prior to the removal of factory components. Finally, check that this system properly matches the make and model of the vehicle and will not interfere with previous or planned modifications.

Removal of Stock System:

1. Apply penetrating lubricant liberally to all exhaust fasteners, hangers and rubber isolators.
2. Loosen the three nuts securing the extension pipe flange to the over-axle pipe.
3. Remove the factory over-axle/tail pipe.
4. Loosen the three nuts securing the extension pipe to the flange directly behind the exhaust filter and remove the extension pipe.
5. Disconnect all exhaust sensors at their connection points to the vehicle.
6. Remove the flange connecting the catalytic converter/diesel particulate filter section (CAT/DPF) of the exhaust to the downpipe.
7. Remove the exhaust hangers from the isolator mounts and remove the CAT/DPF section from the vehicle (this step will require two people, as the stock pipe is heavy).

Installation of MBRP Competition Exhaust:

1. Install the **Front Pipe** by inserting the hangers into the factory isolator mounts and connecting the flange to the downpipe using the **7/16" Hardware** provided. To allow for adjustability, do not fully tighten the hardware until Step 7.
2. The **Extension Pipe** is pre-cut for the 172.4" (crew cab, long box) wheelbase. If installing on a vehicle with a shorter wheelbase, cut the **Extension Pipe** to the appropriate length (**Refer to Diagram**).
3. Install the **Extension Pipe** onto the **Front Pipe** using one of the provided **4" Saddle Clamps**. Do not fully tighten the clamp yet.
4. Install the **Muffler** onto the **Extension Pipe** using a **4" Saddle Clamp**. Insert the **4" Hanger Clamp** into the rearward rubber isolators and place the clamp over the back end of the **Muffler**.
5. Install the **Over-Axle Pipe** into the **Muffler** outlet.
6. Install the **Tail Pipe** by inserting the hanger into the rear isolator mount and inserting the pipe onto the **Over-Axle Pipe**. Secure it using a **4" Hanger Clamp**.
7. Align the exhaust as needed and tighten all clamps and fasteners.

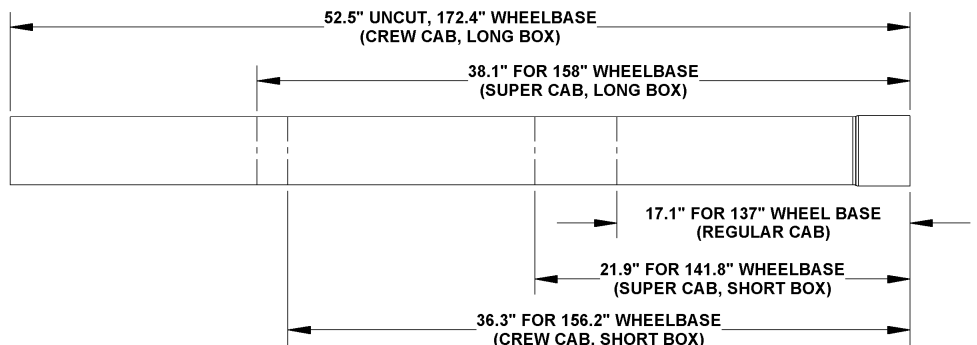

Congratulations! MBRP Competition Exhaust Systems is proud to be a part of your racing and competition success. We know you will enjoy your purchase.