

C6276SLM / C6276PLM

DOWN PIPE BACK, 4" SINGLE EXHAUST
2008-2010 FORD SUPER DUTY, 6.4L POWERSTROKE

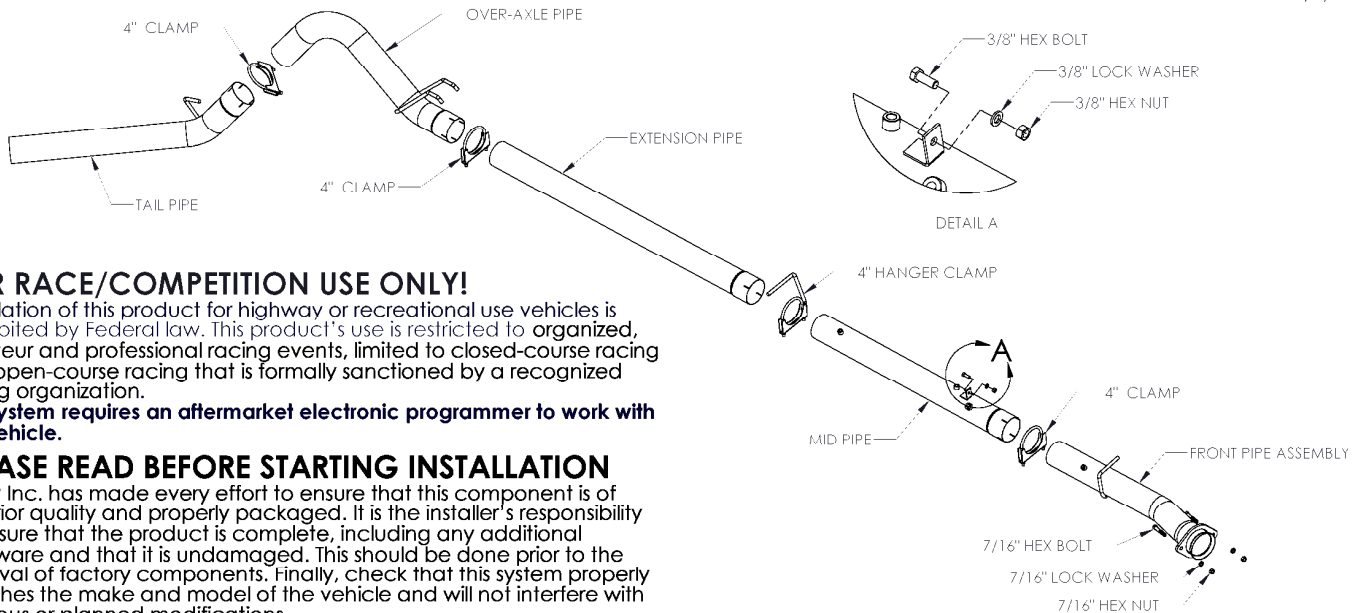

4/1/2011



FOR RACE/COMPETITION USE ONLY!

Installation of this product for highway or recreational use vehicles is prohibited by Federal law. This product's use is restricted to organized, amateur and professional racing events, limited to closed-course racing and open-course racing that is formally sanctioned by a recognized racing organization.

This system requires an aftermarket electronic programmer to work with the vehicle.

PLEASE READ BEFORE STARTING INSTALLATION

MBRP Inc. has made every effort to ensure that this component is of superior quality and properly packaged. It is the installer's responsibility to ensure that the product is complete, including any additional hardware and that it is undamaged. This should be done prior to the removal of factory components. Finally, check that this system properly matches the make and model of the vehicle and will not interfere with previous or planned modifications.

Removal of Stock System:

1. Apply penetrating lubricant liberally to all exhaust fasteners, hangers and rubber insulators.
2. Loosen the nut on the band clamp located behind the particulate filter using a 15mm wrench or socket and remove the tail pipe from the particulate filter.
3. Disconnect all exhaust sensors at their connection points to the vehicle.
4. Remove the flange connecting the catalytic converter and diesel particulate filter section of the exhaust to the downpipe.
5. Remove the exhaust hangers from the isolator mounts and remove the catalytic converter and diesel particulate filter section from the vehicle (this step will require two people, as the stock pipe is heavy). If the sensors are being reused, use caution to avoid damaging them.

Installation of MBRP Competition Exhaust:

1. Install the **Front Pipe** by inserting the hanger into the factory isolator mount and connecting the flange to the downpipe using the **7/16" Hardware** provided.
2. Install the **Mid Pipe** onto the **Front Pipe** using the **4" Clamp** provided. Do not fully tighten the clamp yet.
3. Place the **Hanger Clamp** into the rubber isolator and onto the free end of the **Mid Pipe**. Do not tighten the clamp.
4. The **Extension Pipe** is pre-cut for the 172.4" wheelbase. Cut the **Extension Pipe** to the appropriate length for the installation vehicle (**See Diagram**) and install it onto the **Mid Pipe**.
5. Insert the **Over-Axle Pipe** hangers into the rubber isolators and install the **Over-Axle Pipe** onto the **Extension Pipe** using a **4" Clamp**.
6. Insert the **Tail Pipe** hanger into the rear rubber isolator and install the **Tail Pipe** onto the **Over-Axle Pipe** using a **4" Clamp**.
7. Align the exhaust as needed and tighten all clamps.
8. Re-install the sensors in the provided ports. Attach the pressure sensor bracket using the **3/8" Hardware** provided.

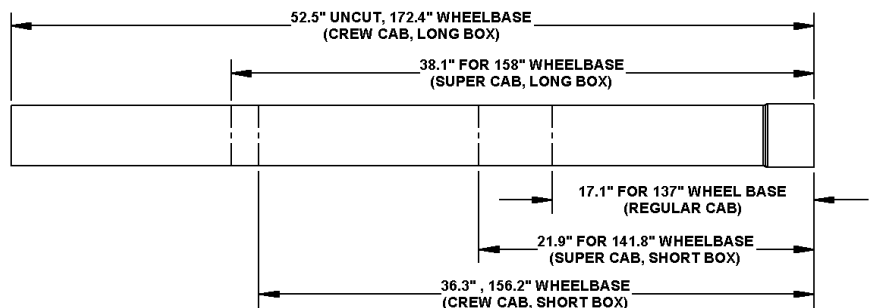

Congratulations! MBRP Competition Exhaust Systems is proud to be a part of your racing and competition success. We know you will enjoy your purchase.