

DS9435

2010 DODGE 6.7L CUMMINS DOWN PIPE

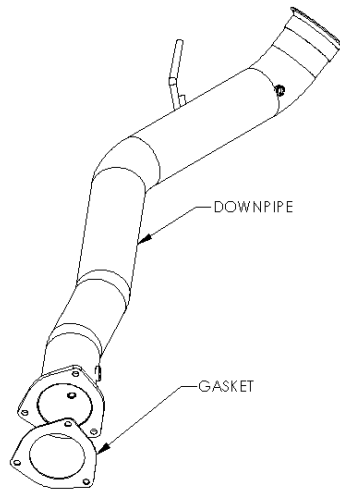

PLEASE READ BEFORE STARTING INSTALLATION

MBRP Inc. has made every effort to ensure that this component is of superior quality and properly packaged. It is the installer's responsibility to ensure that the component is complete, including any additional hardware and that it is undamaged. This should be done prior to the removal of factory components. Finally, check that this system properly matches the make and model of the vehicle and will not interfere with previous or planned modifications.

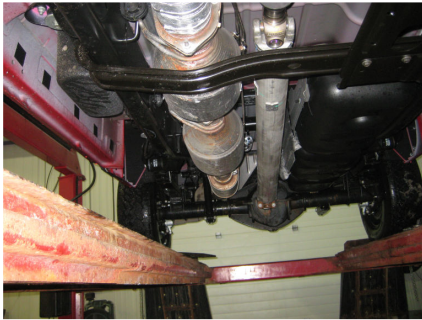

Figure 1

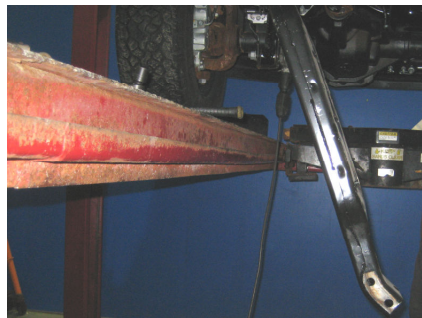

Figure 2

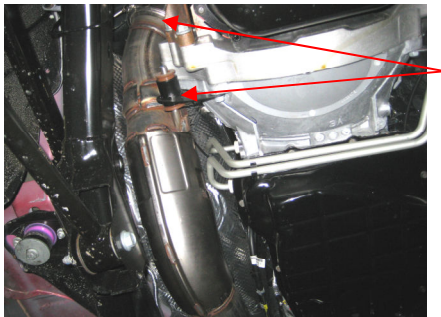

Figure 3

Removal of Stock System:

NOTE: A programmer or other modification of the vehicle's programming may be required in conjunction with this product.

1. Remove the particulate filter and exhaust, be sure to disconnect sensors and lines before lowering. Removing the filter will require two people. **Refer to Figure 1.**
2. Support the transmission and then lower the transmission cross-member. Save hardware for reinstallation. **Refer to Figure 2.**
3. Carefully unplug and then remove the O₂ and EGT sensors along the stock downpipe. Retain the sensors for the installation. Remove the hanger from the bellhousing and loosen the V-band clamp on the down pipe. Remove the stock down pipe. **Refer to Figure 3.**

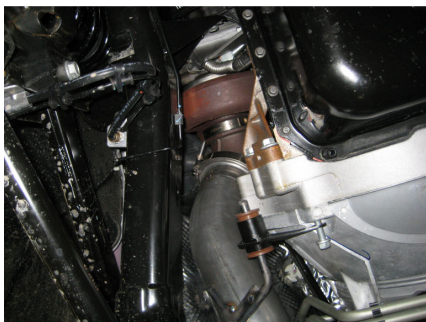

Figure 4



Down Pipe Installation:

1. Install the O₂ and EGT sensors into the new **Down Pipe**.



Figure 5

2. Slide the stock down pipe hanger bracket onto the **Down Pipe** hanger. Install the **Down Pipe** in the same position as the stock down pipe by reattaching the hanger bracket to the bellhousing and then attaching the flared end to the turbo using the stock band clamp. Do not fully tighten until all components are in place. **Refer to Figure 4.**

3. Install the gasket provided to the particulate filter. Attach the particulate filter to the Down Pipe. Reattach the remaining exhaust. Reattach all sensors. **Refer to Figure 5.**

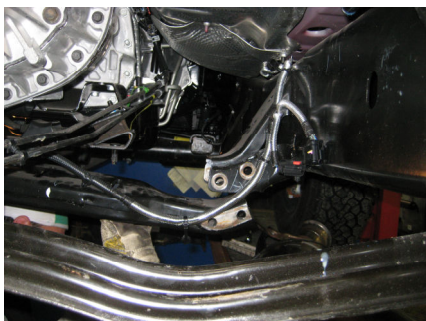

Figure 6

4. Reattach the transmission cross-member. **Refer to Figure 6.**

5. Starting at the front of the exhaust check along the whole length of the system to ensure there is adequate clearance around the fuel and brake lines or any wiring. If any interference is detected relocate or adjust.

6. Start at the front of the exhaust system and begin tightening all connections. Recheck for interference after tightening and adjust if required.

Congratulations! You are ready to begin experiencing the improved power, sound and driving excitement of your MBRP Inc. performance exhaust system. We know you will enjoy your purchase.