

# S4614

2015-19 Golf R MK7/7.5  
2015+ Audi S3/A3  
2.0T  
Resonator Bypass

# MBRP®

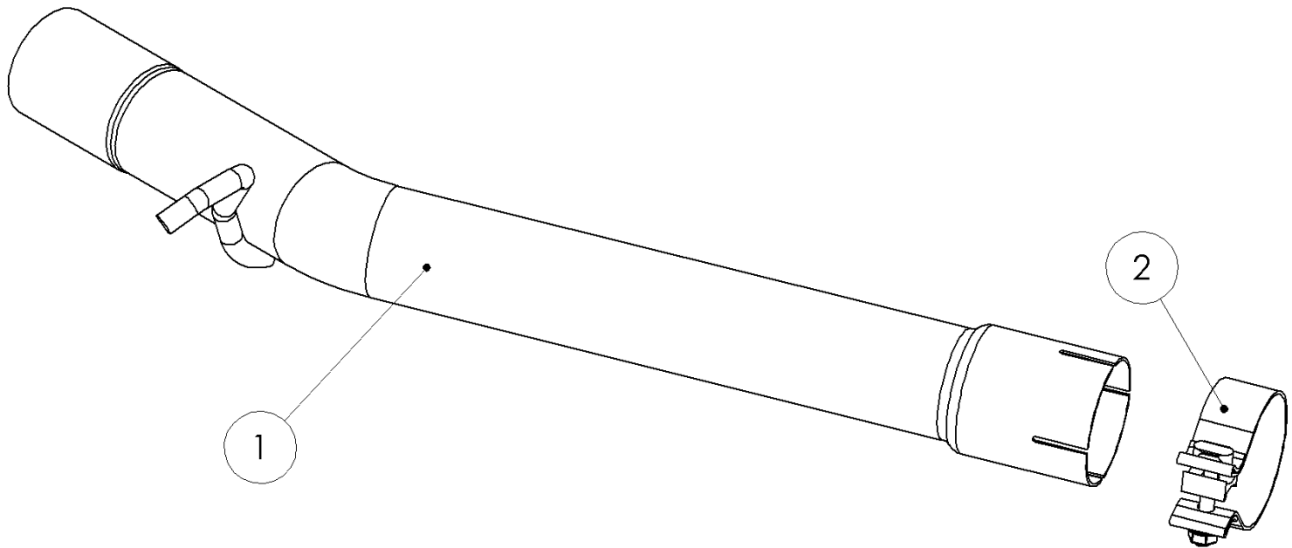

ITEM	DESCRIPTION	QTY
1	RESONATOR BYPASS PIPE	1
2	2.75"CLAMP	1

## PLEASE READ BEFORE STARTING INSTALLATION

While MBRP has made every effort to ensure that all components of this system are of superior quality and properly packaged, it is the installer's responsibility to ensure the following before removal of the factory exhaust:

- that ALL components shown above are present.
- that ALL mating components fit together.
- that there are no damaged components.
- that the system you have purchased is appropriate for your vehicle year, model and configuration.
- that the system will not interfere with any modifications previously installed or planned.
- that you have read and understand these instructions.

If you have any questions or are uncertain about any aspect of the installation of this system to your vehicle please contact your dealer before commencing installation.

# MBRP

## Removal of Stock System



Figure 1



Figure 2



Figure 3



Figure 4

1. Apply penetrating lubricant liberally to all exhaust fasteners, hangers and rubber insulators.

2. Hold the **Resonator Bypass Pipe** in position below the OEM Resonator. The inlet should be positioned in the center of the OEM Band Clamp.

**Refer to Figure 1.**

3. Mark the OEM Pipe at the outlet edge of the **Resonator Bypass Pipe**. Measure and mark a line **3" FORWARD** on the OEM Pipe. This is the location to cut the OEM Pipe.

4. Cut the OEM Pipe.

5. Remove the Hanger from the Rubber Isolator.

6. Loosen the OEM Band Clamp at the inlet of the OEM Catback and slide it forward onto the Front Pipe.

**Refer to Figure 2.**

7. Remove the OEM Resonator from the vehicle.

## Installation of MBRP Performance Exhaust

1. Using the **2.75" Clamp**, install the **Resonator Bypass Pipe** onto the inlet of the remaining OEM Catback

**Refer to Figure 3.**

2. Insert the hanger into the OEM Isolator.

3. Align the inlet of the **Resonator Bypass Pipe** with the outlet of the Front Pipe and secure them with the OEM Band Clamp.

**Refer to Figure 4.**

4. Tighten all hardware and clamps, starting at the front and working rearward to secure the system. Check along the full length of the exhaust system to ensure there is adequate clearance for fuel lines, vent lines, brake lines, frame, bodywork, suspension and any wiring, etc. If there is any interference detected, relocate or adjust to provide adequate clearance.

**Congratulations!** You are ready to begin experiencing the improved power, sound and driving experience of your **MBRP** Performance Exhaust. We know you will enjoy your purchase!