

S5046P

2004-2012 CHEV COLORADO / GMC CANYON 2.8/2.9/3.5/3.7L,
EXTENDED CAB / CREW CAB-SHORT BOX, 2.5" CAT BACK, SINGLE SIDE

MBRP

June 23, 2020

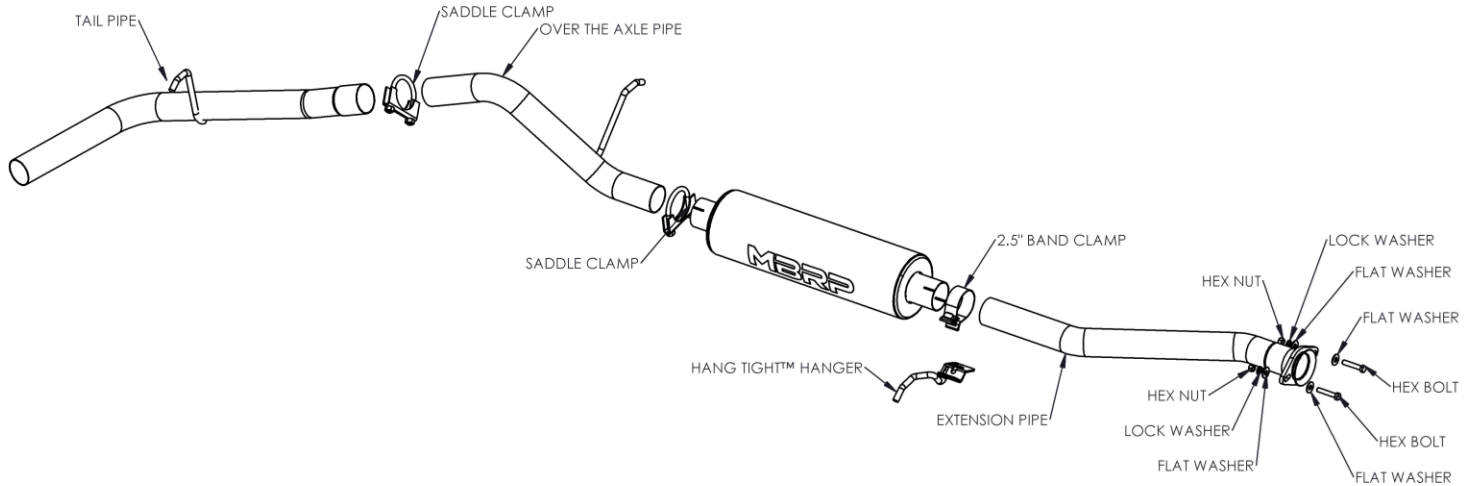

PLEASE READ BEFORE STARTING INSTALLATION

MBRP has made every effort to ensure that all components of this system are of superior quality and properly packaged. It is the installer's responsibility to ensure that all components are present and fit together as shown. Please also ensure that all components are undamaged before removal of the factory exhaust. Finally, check that this system properly matches the make and model of the vehicle and will not interfere with previous or planned modifications.

Removal of Stock System:

1. Apply a penetrating lubricant liberally to all exhaust fasteners, hangers, and rubber insulators.
2. Cut the exhaust in front of the muffler so that it can be removed from the vehicle.
3. Remove the nuts from the studs holding the front flange together and disconnect the exhaust system.
4. Remove the hangers from the rubber insulators. Remove the exhaust from the vehicle.

Installation of MBRP Performance Exhaust:

1. Install the **Extension Pipe** to the existing flange using the fasteners provided.
2. Install the **Hang Tight™ Hanger** onto a **2.5" Band Clamp** using the procedure shown below. (Hang Tight™ Hanger not exactly as shown).

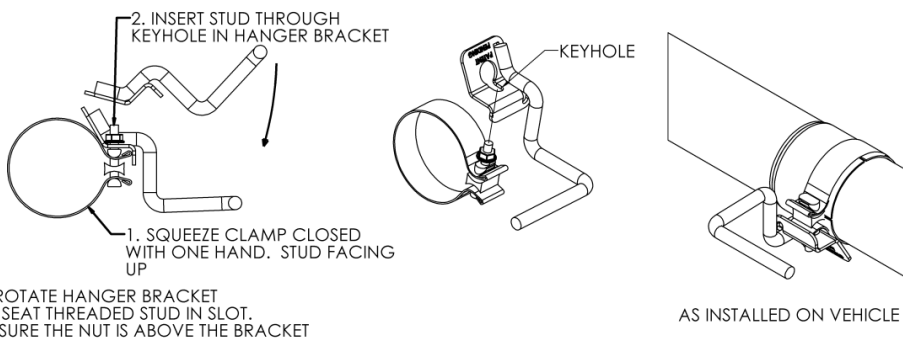

3. Slide the **Hang Tight™ Hanger Clamp Assembly** over the **Extension Pipe** and install the **Muffler** onto the **Extension Pipe**. Install the **Hang Tight™ Hanger** into the existing rubber insulator.
4. Slide a **Clamp** over the outlet side of the **Muffler**. Position the **Over Axle Pipe** and loosely attach it to the **Muffler**. Install the **Over Axle Pipe** hanger into the existing rubber insulator.
5. Slide a **Clamp** over the **Tail Pipe** and install onto the **Over Axle Pipe**.
6. Slide the **Tail Pipe** hanger into rearmost rubber insulator.
7. Align the exhaust as required. Tighten all hardware and clamps, starting at the front and working rearward to secure the system. Check along the full length of the exhaust system to ensure there is adequate clearance for fuel lines, vent lines, brake lines, frame, bodywork, suspension, and any wiring, etc. If there is any interference detected, relocate, or adjust to provide adequate clearance. Ensure all clamp connections are secure and components are unable to rotate or slide. Band clamps require approximately 45 lb-ft (60 N-m) of torque. Verify clearances, system security and band clamp torque after 30-60 miles (50-100 km) of driving.

Congratulations! You are ready to begin enjoying the improved performance and driving experience of your MBRP Performance Exhaust system. We hope you enjoy your purchase.