

S5064

2007-2010 GMC 1500 DENALI, 6.2L
CREW/EXTENDED, 2009-2010 CHEV/GMC
1500 6.2L CREW/EXTENDED, CAT BACK, 3"
SINGLE SIDE

MBRP®

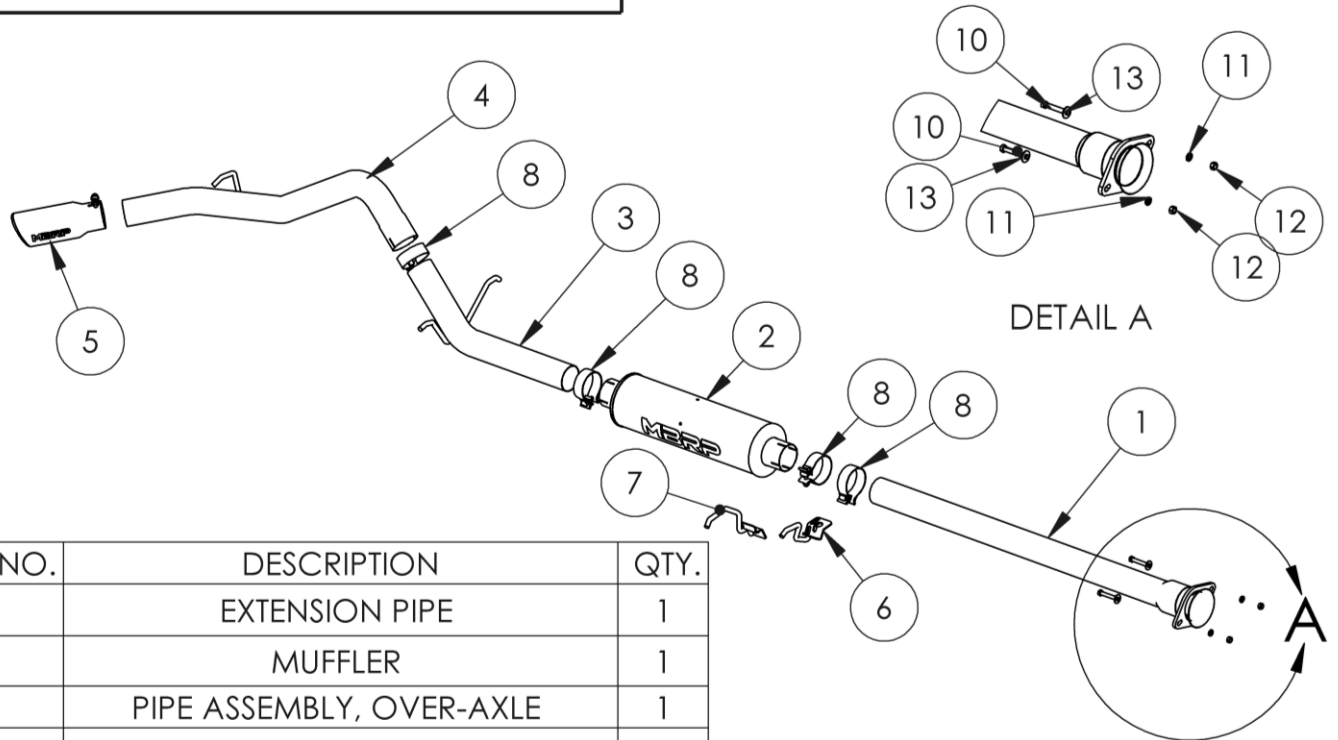

ITEM NO.	DESCRIPTION	QTY.
1	EXTENSION PIPE	1
2	MUFFLER	1
3	PIPE ASSEMBLY, OVER-AXLE	1
4	TAIL PIPE	1
5	EXHAUST TIP	1
6	HANG TIGHT™ HANGER	1
7	HANG TIGHT™ HANGER	1
8	3.0" BAND CLAMPS	4
9	BOLT, HEX 3/8-16x2.5" GR5, ZN	2
10	WASHER, LOCKING, 3/8, ZN	2
11	WASHER, FLAT, 3/8", ZN	2
12	NUT HEX 3/8" GR5 ZN	2

PLEASE READ BEFORE STARTING INSTALLATION

While MBRP Inc. has made every effort to ensure that all components of this system are of superior quality and properly packaged, it is the installer's responsibility to ensure the following before removal of the factory exhaust:

- that ALL components shown above are present.
- that ALL mating components fit together.
- that there are no damaged components.
- that the system you have purchased is appropriate for your vehicle year, model and configuration.
- that the system will not interfere with any modifications previously installed or planned.
- that you have read and understand these instructions.

If you have any questions or are uncertain about any aspect of the installation of this system to your vehicle please contact your dealer before commencing installation.



Figure 1



Figure 2



Figure 3



Figure 4

Removal of stock system:

1. Apply a penetrating lubricant liberally to all exhaust fasteners, hangers and rubber insulators.
2. Remove the nuts from the studs holding the front flange together and disconnect exhaust system. **Refer to Figure 1.**
3. Remove the hangers from the rubber insulators and remove the exhaust from the vehicle.
4. If a hoist or hydraulic lift is not being used the tail pipe may need to be cut to clear the rear axle. **Refer to Figure 2**
5. The studs located in the exhaust flange must be removed. This can be accomplished using a hammer. The studs will be replaced by hardware supplied with the system.

Installation of MBRP Performance Exhaust:

1. Loosely attach the **Extension Pipe** to the flange using the fasteners provided. **Refer to Figure 3**
2. Install the **Hang Tight™ Hanger** onto a **3.0" Band Clamp** using the procedure shown below. (Hang Tight™ Hanger not exactly as Shown)

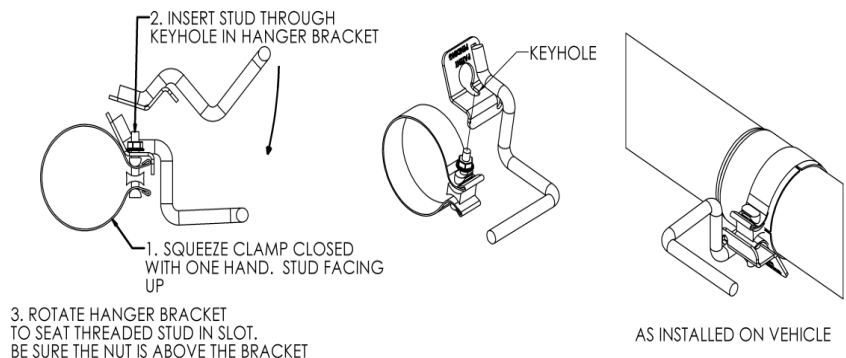



Figure 5



Figure 6

3. Install the **Hang Tight™ Hanger** assembly over the **Extension Pipe** and slide into the OEM rubber isolator located on the frame near the **Extension Pipe**. **Refer to Figure 4.**
4. Install the **Muffler** over the **Extension Pipe** using the other **Hang Tight™ Hanger** assembly and install into the OEM rubber isolator.
5. Slide **3.0” Band Clamp** over the outlet of the **Muffler** and Install the **Over-Axle Pipe** onto the **Muffler** and position it using the two OEM rubber isolators located on the frame.
6. Slide a **3.0” Band Clamp** on the outlet of the **Over-Axle Pipe** then install the **Tail Pipe** onto the **Over-Axle Pipe**. Install the **Tail Pipe** hanger into the factory rubber insulator located directly above the hanger. **Refer to Figure 5.**
7. Install and adjust the **Exhaust Tip** to suit. **Refer to Figure 6.**

8. Align the edge of each band clamp with the edge of the joint it is connecting. Tighten all hardware and clamps, starting at the front and working rearward to secure the system. Check along the full length of the exhaust system to ensure there is adequate clearance for fuel lines, vent lines, brake lines, frame, bodywork, suspension, and any wiring, etc. If there is any interference detected, relocate, or adjust to provide adequate clearance. Ensure all clamp connections are secure and components are unable to rotate or slide. Band clamps require approximately 45 lb-ft (60 N-m) of torque. Verify clearances, system security and band clamp torque after 30-60 miles (50-100 km) of driving.



Congratulations! You are ready to begin experiencing the improved power, sound and driving excitement of your **MBRP** performance exhaust system. We know you will enjoy your purchase.