

S5100

2004-2005 DODGE RAM 1500, 4.7L,
SINGLE/CREW (SHORT BOX) CAB,
CAT BACK, 3", SINGLE SIDE

MBRP®

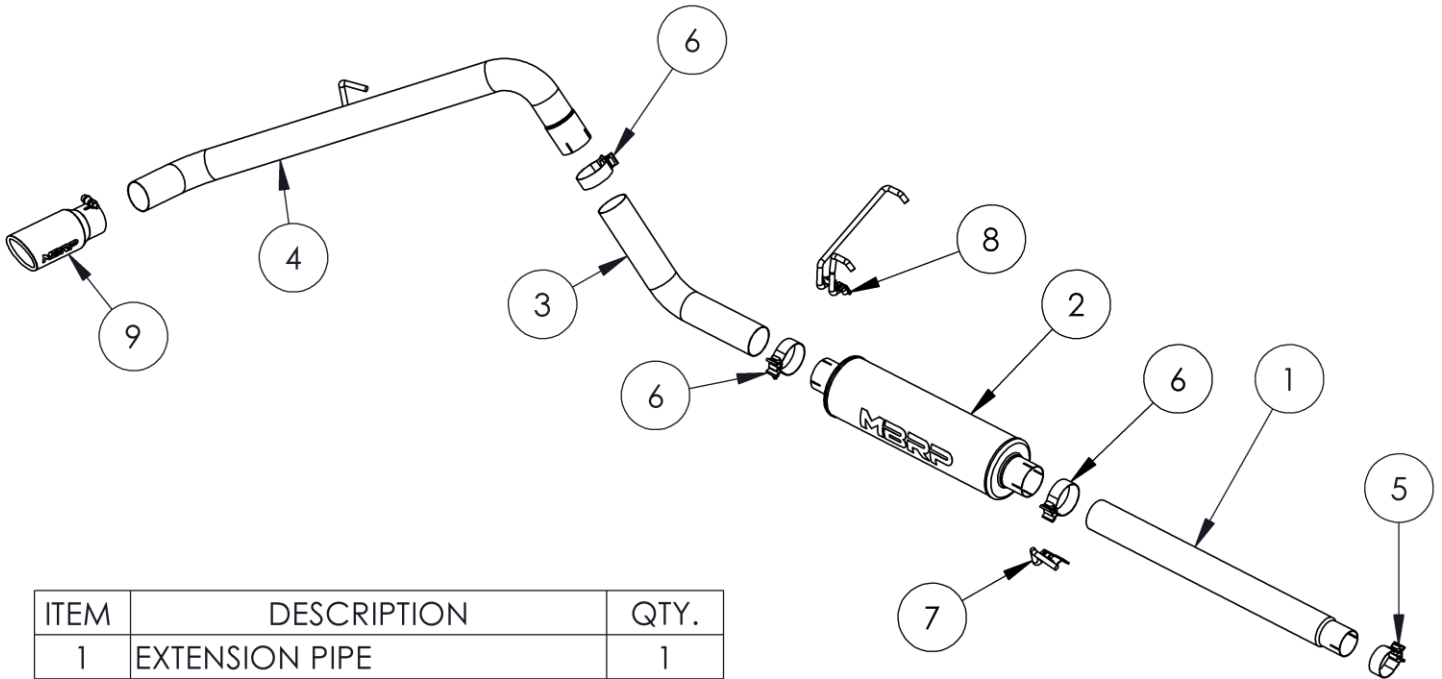

ITEM	DESCRIPTION	QTY.
1	EXTENSION PIPE	1
2	MUFFLER	1
3	OVER-AXLE PIPE	1
4	TAIL PIPE	1
5	2.5" CLAMP	1
6	3.0" CLAMP	3
7	HANG TIGHT™ HANGER	1
8	DUAL HANG TIGHT™ HANGER	1
9	EXHAUST TIP	1

PLEASE READ BEFORE STARTING INSTALLATION

While MBRP has made every effort to ensure that all components of this system are of superior quality and properly packaged, it is the installer's responsibility to ensure the following before removal of the factory exhaust:

- that ALL components shown above are present.
- that ALL mating components fit together.
- that there are no damaged components.
- that the system you have purchased is appropriate for your vehicle year, model and configuration.
- that the system will not interfere with any modifications previously installed or planned.
- that you have read and understand these instructions.

If you have any questions or are uncertain about any aspect of the installation of this system to your vehicle please contact your dealer before commencing installation.

MBRP

Removal of stock system:

1. Apply a penetrating lubricant liberally to all exhaust fasteners, hangers, and rubber insulators.
2. Remove the clamp located behind the muffler. Remove the tail pipe hanger from the rubber insulator and separate the tail pipe from the muffler at the slip joint. Remove the tail pipe from the vehicle.
3. Remove the clamp in front of the muffler and separate the muffler at the slip joint.
4. Remove the hangers from the rubber insulators and remove the muffler assembly from the vehicle.

Installation of MBRP Inc. Performance Exhaust:

NOTE: This system does not require the removal of the spare tire.

Quad Cab Models

1. Install the Hang Tight™ Hangers onto 3.0" Band Clamps using the procedure shown below.
(Hang Tight™ Hangers not exactly as shown).

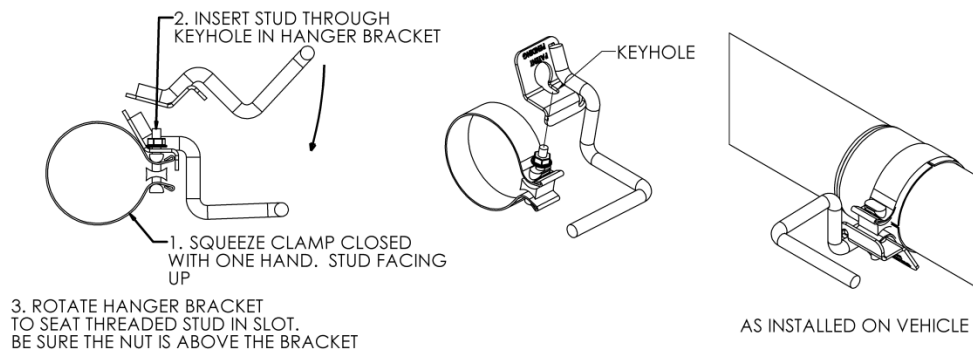

2. Using the **2.5" Clamp**, install the expanded end of the extension pipe over the factory exhaust system behind the "Y" pipe and install the muffler onto the extension pipe with the single **Hang Tight™ Hanger** clamp assembly.
3. Install the **Dual Hang Tight™ Hanger** clamp assembly onto the rear of the **Muffler** and into the factory rubber insulators.
4. Insert the **Over Axle Pipe** into the **Muffler** and secure loosely with the **Dual Hang Tight™ Hanger** clamp assembly.
5. Feed the **Tail Pipe** over the axle and loosely install it into the **Over Axle Pipe** with a **3" Clamp**.
6. Install the tailpipe hanger through the factory rubber insulator.
7. Install the mirror polished tip. It is recommended to install it at this point to assist with the final system alignment.
8. Align the exhaust as required before tightening **Clamps**.
9. Tighten all hardware and clamps, starting at the front and working rearward to secure the system. Check along the full length of the exhaust system to ensure there is adequate clearance for fuel lines, vent lines, brake lines, frame, bodywork, suspension, and any wiring, etc. If there is any interference detected, relocate, or adjust to provide adequate clearance. Ensure all clamp connections are secure and components are unable to rotate or slide. Band clamps require approximately 45 lb-ft (60 N-m) of torque. Verify clearances, system security and band clamp torque after 30-60 miles (50-100 km) of driving.

MBRP

Regular Cab Models

1. Install the Hang Tight™ Hangers onto 3.0" Band Clamps using the procedure shown below. (Hang Tight™ Hangers not exactly as shown).

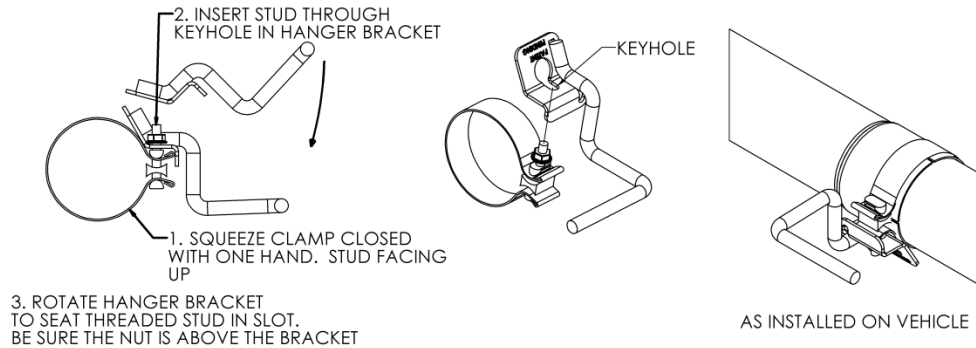

2. Temporarily install the **Muffler** by placing both **Hang Tight™ Hanger** clamp assemblies onto the **Muffler** (Single hanger on the front, Dual on the rear). Install the **Hang Tight™ Hangers** into the respective factory rubber insulators. Measure from the front of the **Muffler** to the "Y" pipe. This will give you the required length to cut the extension pipe. Remove the **Muffler** and **Hang Tight™ Hanger** clamp assemblies.
3. Cut the **Extension Pipe** to the required length. Using the **2.5" Clamp**, install the expanded end of the **Extension Pipe** over the factory exhaust system behind the "Y" pipe and install the muffler onto the extension pipe with the single **Hang Tight™ Hanger** clamp assembly.
4. Install the **Dual Hang Tight™ Hanger** clamp assembly onto the rear of the **Muffler** and into the factory rubber insulators.
5. Insert the **Over Axle Pipe** into the **Muffler** and secure loosely with the **Dual Hang Tight™ Hanger** clamp assembly.
6. Feed the **Tail Pipe** over the axle and loosely install it into the **Over Axle Pipe** with a **3" Clamp**.
7. Install the tailpipe hanger through the factory rubber insulator.
8. Install the mirror polished tip. It is recommended to install it at this point to assist with the final system alignment.
9. Align the exhaust as required before tightening **Clamps**.
10. Tighten all hardware and clamps, starting at the front and working rearward to secure the system. Check along the full length of the exhaust system to ensure there is adequate clearance for fuel lines, vent lines, brake lines, frame, bodywork, suspension, and any wiring, etc. If there is any interference detected, relocate, or adjust to provide adequate clearance. Ensure all clamp connections are secure and components are unable to rotate or slide. Band clamps require approximately 45 lb-ft (60 N-m) of torque. Verify clearances, system security and band clamp torque after 30-60 miles (50-100 km) of driving.

Congratulations! You are ready to begin enjoying the improved performance and driving experience of your MBRP Inc. Performance Exhaust system. We hope you enjoy your purchase.