

S5209

2021-UP FORD F150,
2.7L ECOBOOST, 3.5L ECOBOOST, 5.0L,
EXCL. POWERBOOST, CAT-BACK, 4.0" SINGLE
SIDE, RACE VERSION

MBRP®

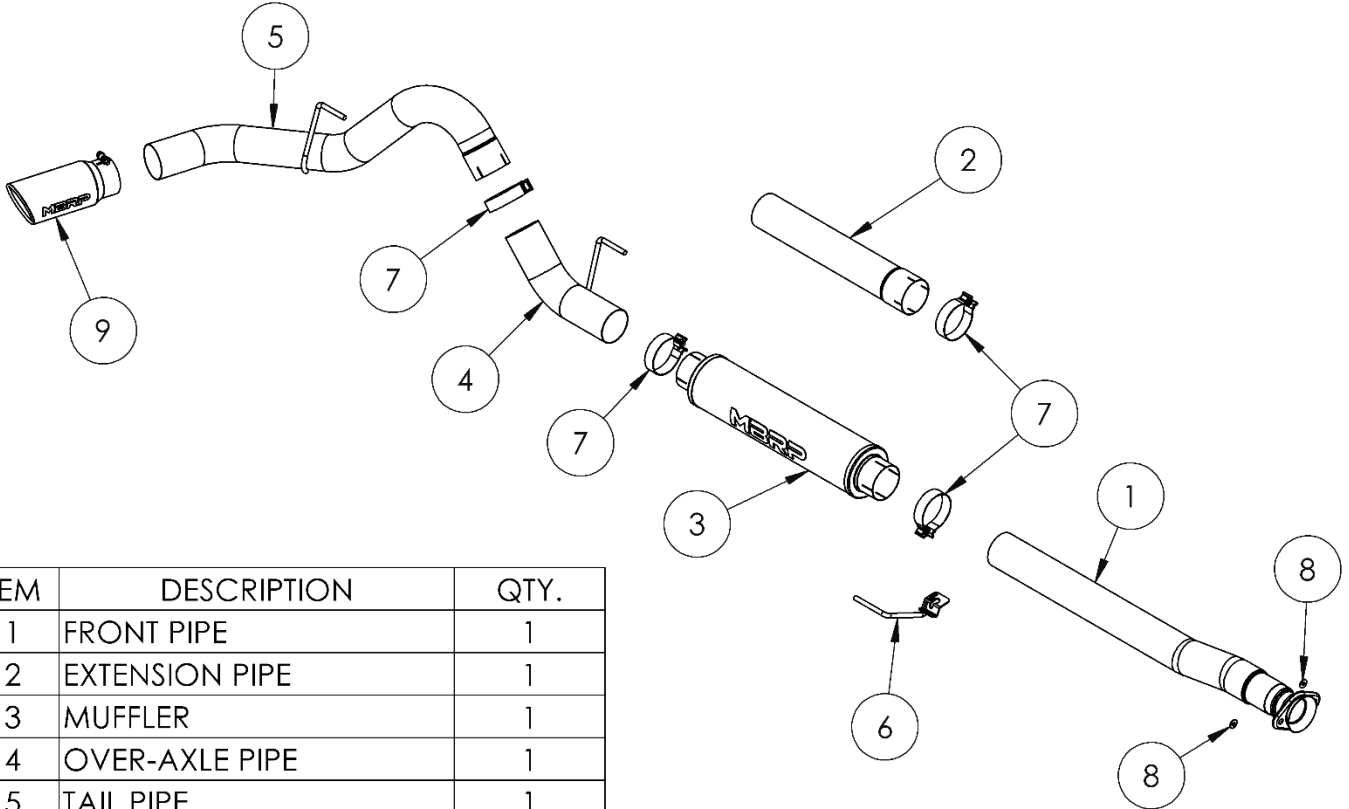

ITEM	DESCRIPTION	QTY.
1	FRONT PIPE	1
2	EXTENSION PIPE	1
3	MUFFLER	1
4	OVER-AXLE PIPE	1
5	TAIL PIPE	1
6	HANG TIGHT™ HANGER	1
7	4" BAND CLAMP	4
8	3/8" FLAT WASHER	2
9	EXHAUST TIP	1

PLEASE READ BEFORE STARTING INSTALLATION

While MBRP has made every effort to ensure that all components of this system are of superior quality and properly packaged, it is the installer's responsibility to ensure the following before removal of the factory exhaust:

- that ALL components shown above are present.
- that ALL mating components fit together.
- that there are no damaged components.
- that the system you have purchased is appropriate for your vehicle year, model and configuration.
- that the system will not interfere with any modifications previously installed or planned.
- that you have read and understand these instructions.

If you have any questions or are uncertain about any aspect of the installation of this system to your vehicle please contact your dealer before commencing installation.

MBRP

Removal of Stock System:

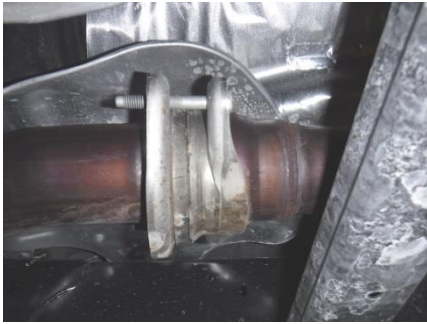

Figure 1

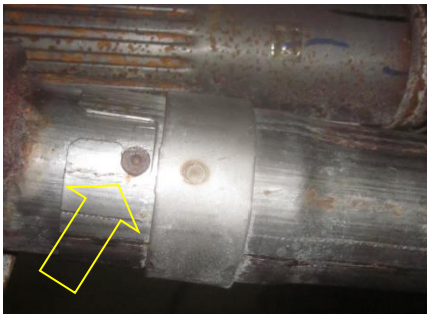

Figure 2



Figure 4

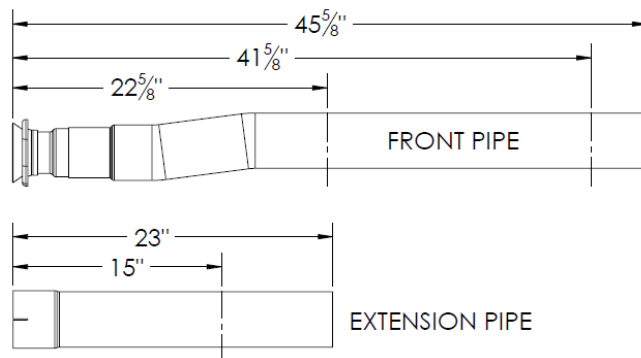

Figure 5

1. Apply a penetrating lubricant liberally to all hangers and rubber insulators.
2. Loosen the factory clamp in front of the muffler.
3. Loosen the factory extension pipe flange bolts.
Refer to Figure 1.
4. Rotate the factory extension pipe to release the factory muffler inlet locking boss.
Refer to Figure 2.
5. Remove the factory muffler assembly from the hangers and remove from the vehicle.
6. Remove the factory extension pipe bolts and remove the factory extension pipe from the vehicle.

Installation of MBRP Performance Exhaust:

1. Determine the overall length of the **Front Pipe** and **Extension Pipe** (if required).
Refer to Figure 3 (Below).



WHEELBASE	FRONT PIPE LENGTH	EXTENSION PIPE LENGTH
122" RC 6.5' BOX	22 5/8"	NONE
141" RC 8' BOX	41 5/8"	NONE
145" EC 6.5' BOX/ SC 5.5' BOX	45 5/8" (NO CUT)	NONE
157" SC 6.5' BOX	45 5/8" (NO CUT)	15"
164" EC 8' BOX	45 5/8" (NO CUT)	23" (NO CUT)

Figure 3.

2. Loosely install the **Front Pipe** using the factory bolts and supplied **Flat Washers**.
Refer to Figure 4.
3. Slide a **4" Clamp** over the **Front Pipe** and install the **Extension Pipe** onto the **Front Pipe** if required.

MBRP



Figure 6



Figure 7

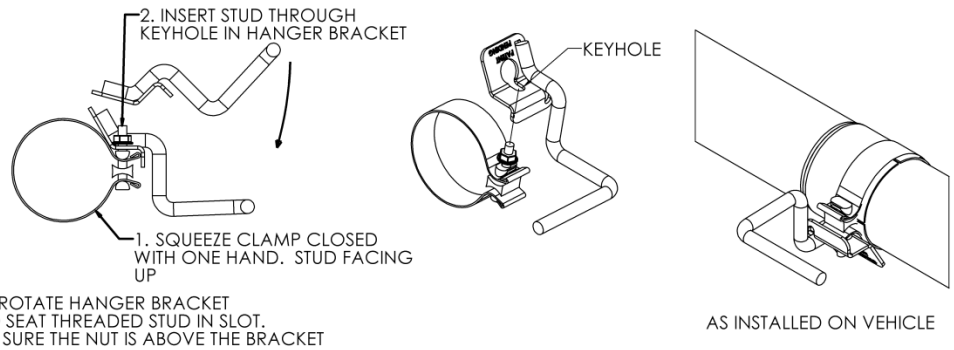

Figure 8



Figure 9

4. Install the **Hang Tight™ Hanger** onto a **4.0” Clamp** using the procedure shown below. Loosely install the assembly to the **Extension Pipe** (or **Front Pipe** if the **Extension Pipe** is not required) and place the hanger into the second factory isolator. (Hang Tight™ Hanger not exactly as shown) **Refer to Figure 5.**



5. Install the **Muffler** onto **Extension Pipe** and lightly secure with the **Hang Tight™ Hanger Clamp**. Snug, but do not completely tighten at this time. **Refer to Figure 6.**

6. Place a **4” Clamp** over the **Muffler** outlet and insert the **Over-Axle Pipe** into the **Muffler** and factory isolator. **Refer to Figure 7.**

7. Install a **4” Clamp** and the **Tail Pipe** onto the **Over-Axle Pipe** and into the factory isolator. Snug, but do not completely tighten the **4” Clamp**. **Refer to Figure 8.**

8. Install the **Exhaust Tip** and adjust to your liking. **Refer to Figure 9.**

9. Align the edge of each band clamp with the edge of the joint it is connecting. Tighten all hardware and clamps, starting at the front and working rearward to secure the system. Check along the full length of the exhaust system to ensure there is adequate clearance for fuel lines, vent lines, brake lines, frame, bodywork, suspension and any wiring, etc. If there is any interference detected, relocate or adjust to provide adequate clearance. Ensure all clamp connections are secure and components are unable to rotate or slide. Band clamps require approximately 45 lb-ft (60 after 30-60 miles (50-100 km) of driving.

Congratulations! You are ready to begin experiencing the improved power, sound and driving experience of your **MBRP** performance exhaust system. We know you will enjoy your purchase.