

# S5533

2018-UP JEEP WRANGLER (JL) 4-DOOR/2-DOOR, 2.0L & 3.6L, 2.5" SINGLE, HIGH-CLEARANCE

# MBRP®

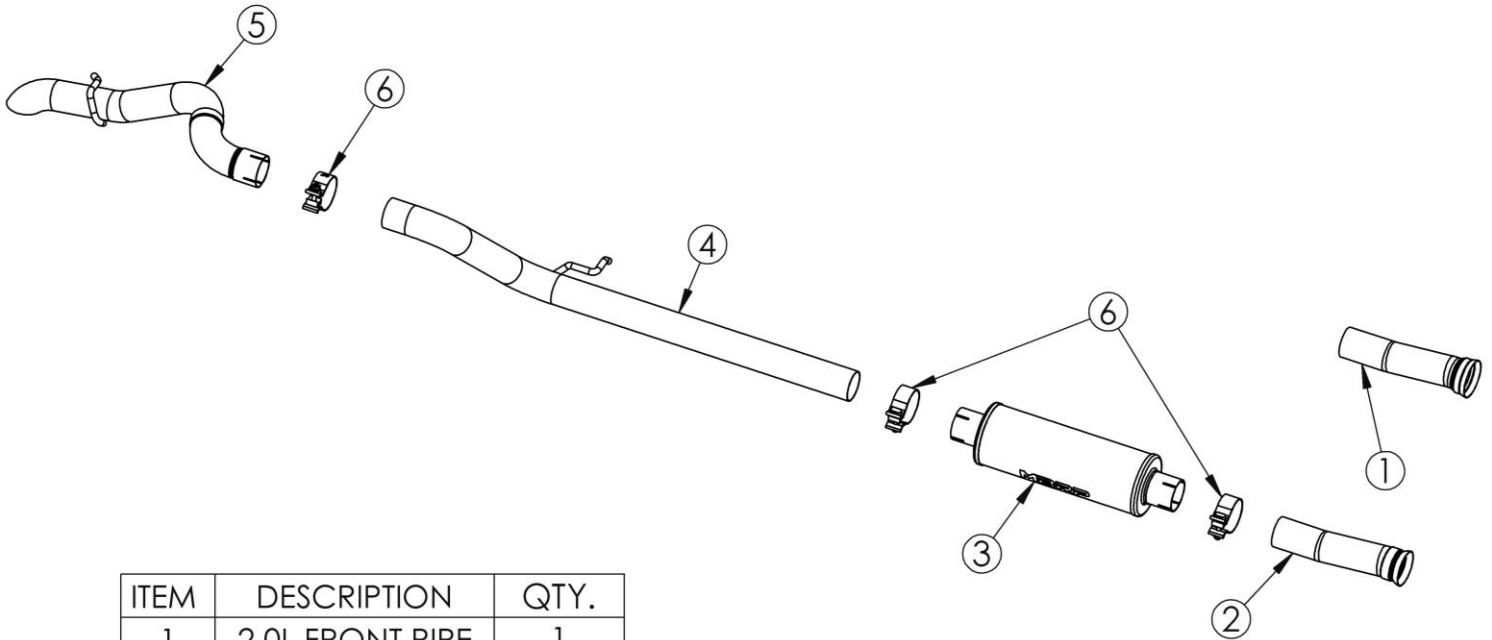

ITEM	DESCRIPTION	QTY.
1	2.0L FRONT PIPE	1
2	3.6L FRONT PIPE	1
3	MUFFLER	1
4	OVER-AXLE PIPE	1
5	TAIL PIPE	1
6	2.5" CLAMP	3

## PLEASE READ BEFORE STARTING INSTALLATION

While MBRP has made every effort to ensure that all components of this system are of superior quality and properly packaged, it is the installer's responsibility to ensure the following before removal of the factory exhaust:

- that ALL components shown above are present.
- that ALL mating components fit together.
- that there are no damaged components.
- that the system you have purchased is appropriate for your vehicle year, model and configuration.
- that the system will not interfere with any modifications previously installed or planned.
- that you have read and understand these instructions.

If you have any questions or are uncertain about any aspect of the installation of this system to your vehicle please contact your dealer before commencing installation.

# MBRP

## Removal of Stock System:



Figure 1

1. Apply a penetrating lubricant liberally to all exhaust fasteners, hangers and rubber insulators.

2. Start to remove the exhaust by loosening the clamp just before the muffler on the driver's side.

**Refer to Figure 1.**

3. The muffler can be removed by removing the hangers from the rubber isolators, one on each side.

**Refer to Figure 2.**



Figure 2

4. Loosen the clamp attached to the extension pipe and remove the pipe from the stock isolator.

**Refer to Figure 3.**

5. In order to reuse the stock clamp, pry back the small tab on the extension pipe so that the clamp can be removed.

**Refer to Figure 3.**

## Installation of MBRP Performance Exhaust



Figure 3

1. Install the **Front Pipe** using the stock clamp. Leave the clamp loose enough to rotate the pipe for adjustment.

Note: The larger diameter flare front pipe fits the 2.0L

**Refer to Figure 4.**

2. Slide a 2 1/2" **Clamp** over the **Front Pipe** and then install the **Muffler** onto the **Front Pipe**. Orient the muffler such that the louvers (inside the muffler) are open to the front of the vehicle. See diagram.



Figure 4

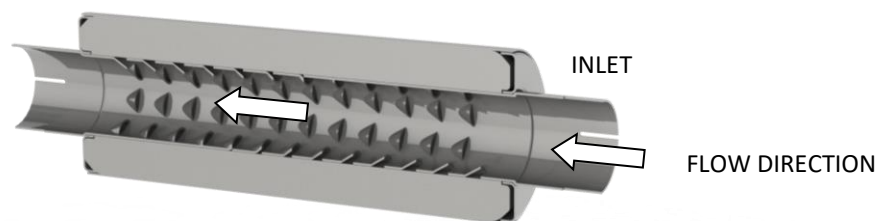

# MBRP



**Figure 5**

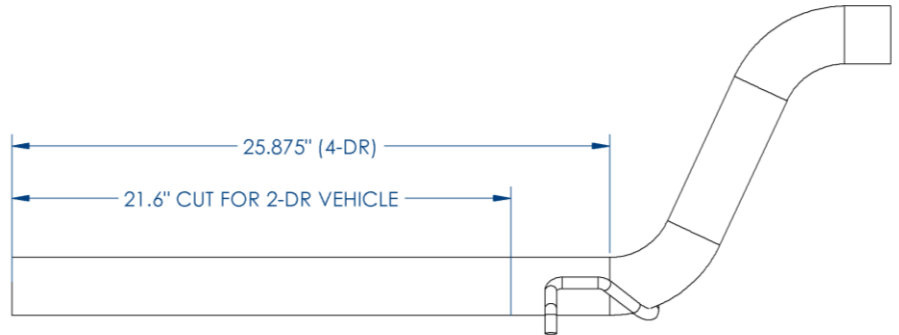

**Figure 6**

3. Slide a 2 ½” **Clamp** onto the **Muffler** outlet. Install the **Over-Axle Pipe** into the **Muffler**, then install the hanger into the factory rubber insulator.

**Refer to Figure 5.**

Note: For the short wheelbase (2-DR) vehicle, the long end of the **Over-Axle Pipe** must be shortened by 21.6”. See diagram.



4. Remove the rubber insulator from the stock rear location (driver-side) and slide it onto the **Tail Pipe** hanger. Slide a 2 ½” **Clamp** onto the **Over-Axle Pipe** and install the **Tail Pipe**. Reinstall the rubber insulator back onto the stock support.

**Refer to Figure 6.**

5. Tighten all hardware and clamps, starting at the front and working rearward to secure the system. Check along the full length of the exhaust system to ensure there is adequate clearance for fuel lines, vent lines, brake lines, frame, bodywork, suspension and any wiring, etc. If there is any interference detected, relocate or adjust to provide adequate clearance. Ensure all clamp connections are secure and components are unable to rotate or slide. Band clamps require approximately 45 lb-ft (60 N-m) of torque. Verify clearances, system security and band clamp torque after 30-60 miles (50-100 km) of driving.

**Congratulations!** You are ready to begin experiencing the improved power, sound and driving experience of your **MBRP** performance exhaust system. We hope you enjoy your purchase.