

S5604

2018-2021 AUDI SQ5, 3.0T, AXLE-BACK, 2.5"
DUAL REAR
EXCLUDES FACTORY QUAD TIP AND AIR
SUSPENSION EQUIPPED VEHICLES

MBRP®

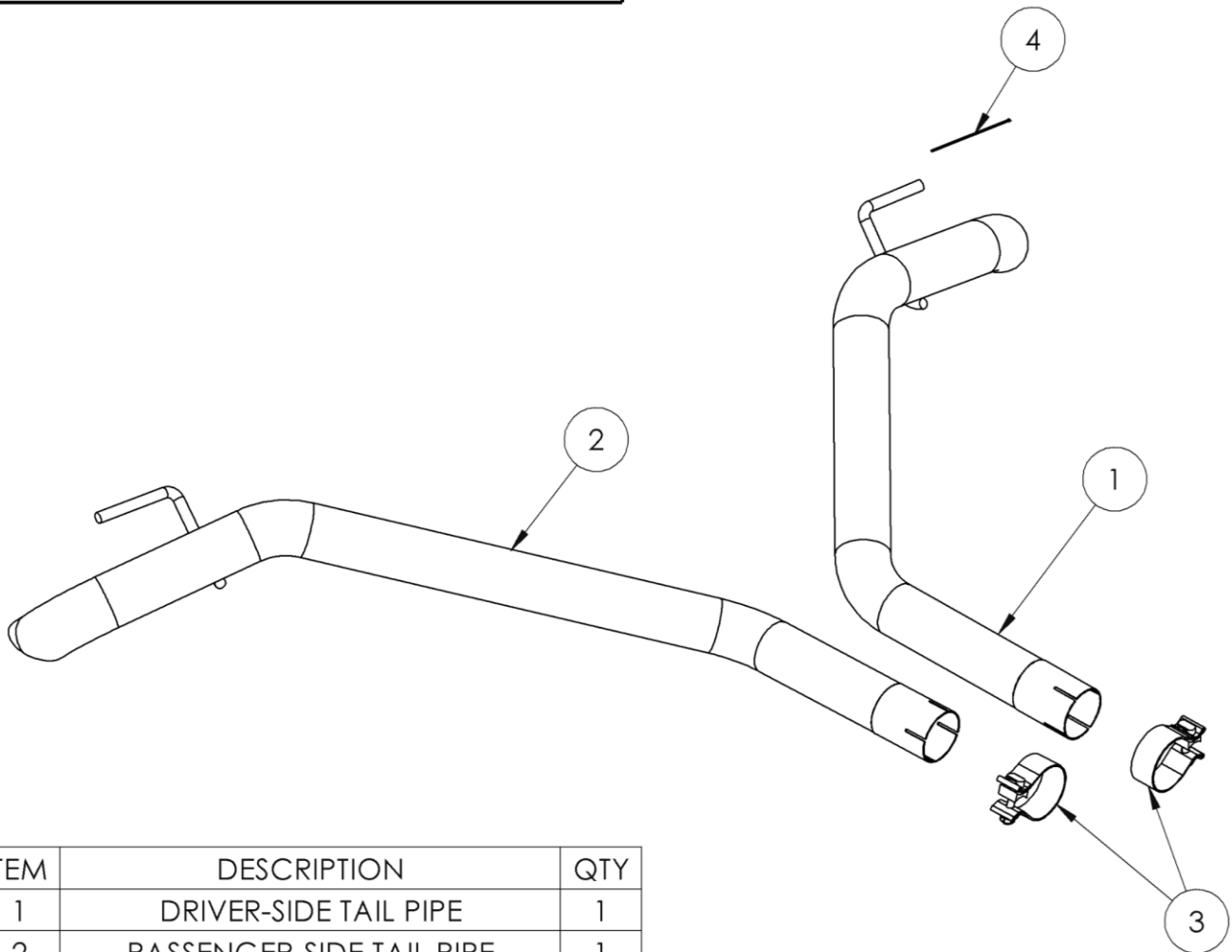

| ITEM | DESCRIPTION | QTY |
|------|--------------------------|-----|
| 1 | DRIVER-SIDE TAIL PIPE | 1 |
| 2 | PASSENGER-SIDE TAIL PIPE | 1 |
| 3 | 2.38" CLAMP | 2 |
| 4 | CABLE TIE | 1 |

PLEASE READ BEFORE STARTING INSTALLATION

While MBRP has made every effort to ensure that all components of this system are of superior quality and properly packaged, it is the installer's responsibility to ensure the following before removal of the factory exhaust:

- that ALL components shown above are present.
- that ALL mating components fit together.
- that there are no damaged components.
- that the system you have purchased is appropriate for your vehicle year, model and configuration.
- that the system will not interfere with any modifications previously installed or planned.
- that you have read and understand these instructions.

If you have any questions or are uncertain about any aspect of the installation of this system to your vehicle please contact your dealer before commencing installation.

MBRP

Removal of Stock System



Figure 1



Figure 2



Figure 3



Figure 4

1. Apply a penetrating lubricant liberally to tail pipe hangers and rubber isolators.
2. Unplug the valve located on the tail pipe on driver-side end.
3. Measure 5.5" from the center of the hanger, located after the center muffler towards the outlet. Mark and cut the driver-side exhaust.
Refer to Figure 1 & 3.
4. Measure 8.0" using the same reference. Mark and cut the passenger-side exhaust.
Refer to Figure 2 & 3.
5. Unbolt both the isolator assemblies and remove the rear muffler from the vehicle.
Refer to Figure 4.

Installation of MBRP Performance Exhaust:

1. Secure the factory wiring previously unplugged from valve with the provided **Cable Tie**.
2. Remove the factory isolator assemblies from the factory exhaust and install them onto the **Passenger- Side Tail Pipe** and **Driver-Side Tail Pipe** hangers.
3. Using a **2.38" Clamp**, install the **Passenger- Side Tail Pipe** onto the factory exhaust and reinstall the isolator assembly using the factory hardware.
Refer to Figure 5 & 6.
4. Repeat step 2 for the **Driver-Side Tail Pipe**.
Refer to Figure 5 & 7.

MBRP



Figure 5



Figure 6



Figure 7

4. Align the edge of each band clamp with the edge of the joint it is connecting. Tighten all hardware and clamps, starting at the front and working rearward to secure the system. Check along the full length of the exhaust system to ensure there is adequate clearance for fuel lines, vent lines, brake lines, frame, bodywork, suspension, and any wiring, etc. If there is any interference detected, relocate, or adjust to provide adequate clearance. Ensure all clamp connections are secure and components are unable to rotate or slide. Band clamps require approximately 45 lb-ft (60 N-m) of torque. Verify clearances, system security and band clamp torque after 30- 60 miles (50-100 km) of driving.



Congratulations! You are ready to begin experiencing the improved power, sound and driving experience of your **MBRP** performance exhaust system. We know you will enjoy your purchase.