

# S6004

2001-2007 CHEV/GMC 2500/3500,  
EXTENDED CAB/CREW CAB, 6.6L DURAMAX,  
CAT-BACK, 4.0" SINGLE SIDE

# MBRP®

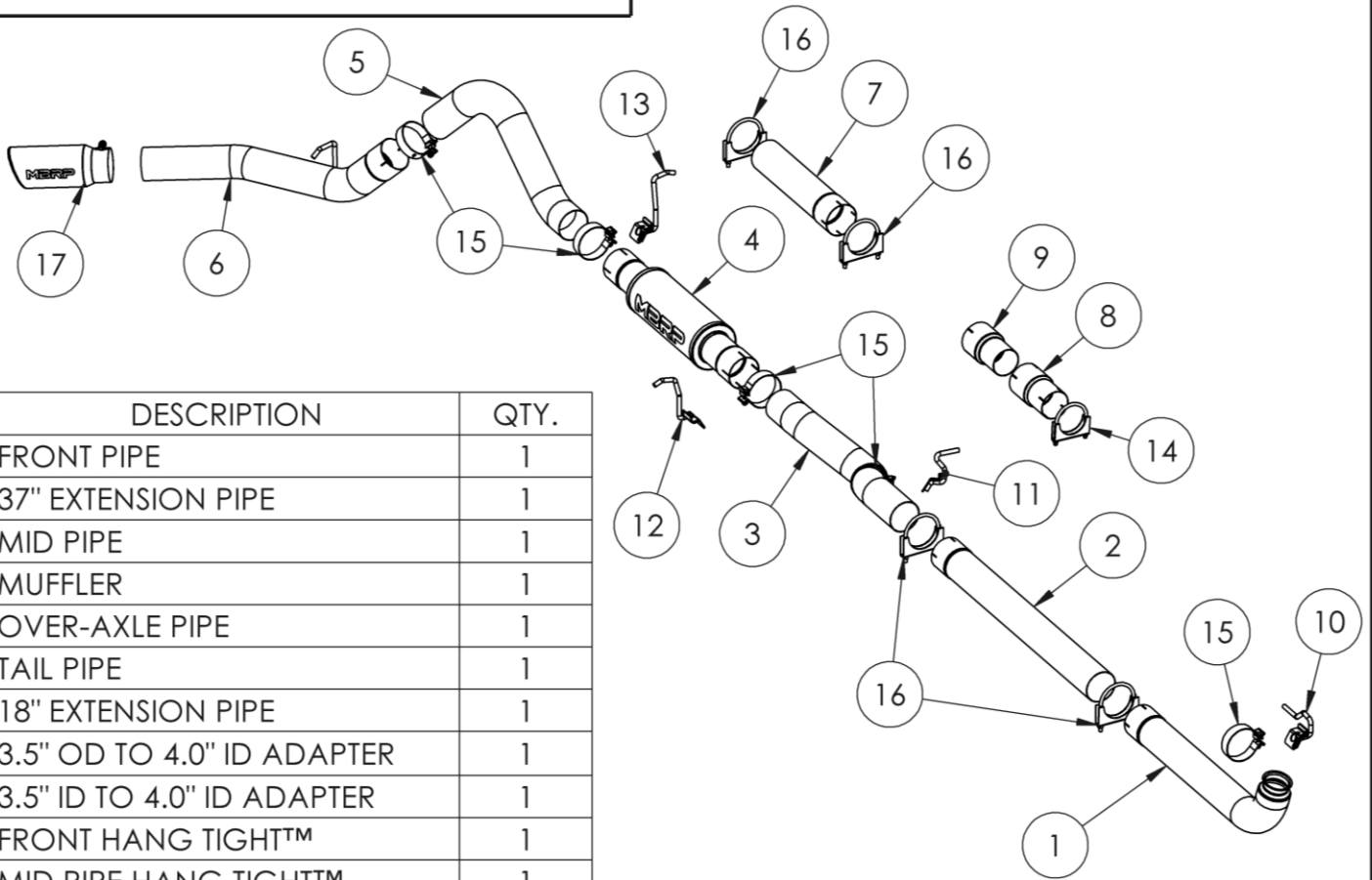

ITEM	DESCRIPTION	QTY.
1	FRONT PIPE	1
2	37" EXTENSION PIPE	1
3	MID PIPE	1
4	MUFFLER	1
5	OVER-AXLE PIPE	1
6	TAIL PIPE	1
7	18" EXTENSION PIPE	1
8	3.5" OD TO 4.0" ID ADAPTER	1
9	3.5" ID TO 4.0" ID ADAPTER	1
10	FRONT HANG TIGHT™	1
11	MID PIPE HANG TIGHT™	1
12	SHORT MUFFLER HANG TIGHT™	1
13	LONG MUFFLER HANG TIGHT™	1
14	3 1/2" CLAMP	1
15	4" BAND CLAMP	5
16	4" CLAMP	4
17	EXHAUST TIP	1

NOTE: MUFFLER MAY NOT BE EXACTLY  
AS SHOWN

## PLEASE READ BEFORE STARTING INSTALLATION

While MBRP has made every effort to ensure that all components of this system are of superior quality and properly packaged, it is the installer's responsibility to ensure the following before removal of the factory exhaust:

- that ALL components shown above are present.
- that ALL mating components fit together.
- that there are no damaged components.
- that the system you have purchased is appropriate for your vehicle year, model and configuration.
- that the system will not interfere with any modifications previously installed or planned.
- that you have read and understand these instructions.

If you have any questions or are uncertain about any aspect of the installation of this system to your vehicle please contact your dealer before commencing installation.

# MBRP®



**Figure 1**



**Figure 2**



**Figure 3**



**Figure 4**

## Removal of stock system:

1. Apply penetrating lubricant liberally to all exhaust fasteners, hangers and rubber insulators.
2. If vehicle is not equipped with a catalytic converter, proceed to step 3. If installing Cat Back system, for 01-05 cut front pipe 2.75" behind four bolt flange. Proceed to step 4.  
**See Figure 1.**  
For 06-07 loosen the band clamp behind the catalytic converter. Proceed to step 4.
3. If the vehicle is not equipped with a catalytic converter disconnect the four bolt flange located approximately under the passenger seat.  
**See Figure 1.**
4. Remove the exhaust system from the rubber insulators and remove from under the vehicle. If a hoist is not available for use it may be necessary to cut the tail pipe behind the muffler for removal of the system.

If the vehicle is equipped with a catalytic converter, continue to Installation step 3.

### **Steps 5&6 are for Down Pipe Back systems only**

5. Unbolt the OEM hanger from the transmission and remove. Do not discard the hanger as it is required for the installation.  
**See Figure 2.**
6. Loosen the factory band clamp and remove the stock front pipe. Do not discard the band clamp as it is required for the installation.  
**See Figure 3.**

# MBRP®

## Installation of MBRP Performance Exhaust:

**Note:** Vehicles originally equipped with a catalytic converter must retain the factory catalytic converter. Removal of the catalytic converter may be a violation of federal or local regulations.



**Figure 5**

(Hanger may not be same as shown)



**Figure 6**

1. For Cat Back systems proceed to step 3. For 01-04 Downpipe-back systems install the **Front Pipe** onto the factory down pipe using the band clamp removed previously. Do not fully tighten to allow for adjustment. See **Figure 4**.
2. Install the hanger removed previously by sliding the outside hole in the rubber insulator over the **Front Hang Tight™** (See figure 7 for Hang Tight instructions and Figure 10 for hanger clarification) and re-connect to the transmission.

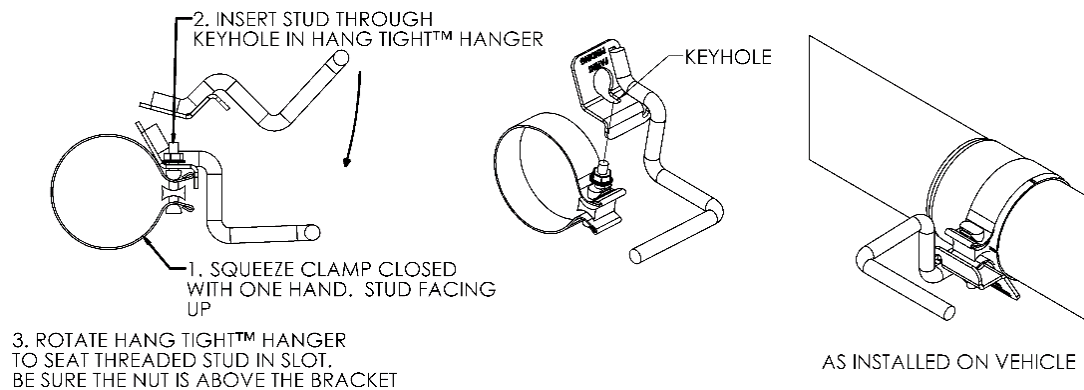

**Figure 7**

3. For 06-07 Cat Back systems only. Place the **3.5" OD to 4.0" ID Adaptor** provided into the factory band clamp located behind the catalytic converter.
4. For 01-05 Cat Back systems only. Place the **3.5" ID to 4.0" ID Adaptor** over the pipe behind the four-bolt flange (cut in the stock removal steps). Secure it with the **3.5" Clamp** provided.
5. Install the **37" Extension Pipe** into the **Front Pipe** or **Adaptor**. For extended cab trucks, approximately 9½" needs to be cut off the end of the **37" Extension Pipe**. Next position the **Mid Pipe** bend around & under the cross member. Rotate the pipe to position the bend toward the driveshaft. (**Installation tip:** Temporarily hang the **Muffler**, **Over-Axle Pipe**, and **Tail Pipe** in place and measure to the **Adaptor** to verify the length required).
6. Position the **Mid Pipe** as shown and loosely install the **Mid Pipe Hang Tight™** This will support the **Extension Pipe** during the **Muffler** installation. See **Figure 5**.
7. Crew Cab & Extended Cab long box trucks require the use of the **18" Extension Pipe** provided. This is to be positioned between the **Muffler** and the **Mid Pipe**.  
Note: The **18" Extension Pipe** is NOT required with short box trucks.
8. Install the **Muffler** on the **Extension Pipe** or **Mid Pipe** along with the **Short Muffler Hang Tight™**. See **Figure 6**.

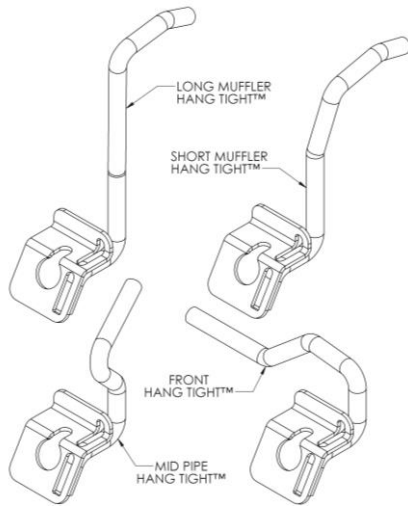

**Figure 8**

Hanger may not be same as shown)



**Figure 9**



**Figure 10**

9. Install the **Long Muffler Hang Tight™** at the connection between the **Muffler** and the **Over-Axle Pipe** and into the OEM rubber hanger at this position.  
**See Figure 8.**
10. Install the **4" Band Clamp** over the **Tail Pipe** and then install the **Tail Pipe** to the **Over-Axle Pipe**. Install the **Tail Pipe Hanger** into the OEM hanger, adjust for best axle clearance and **Tail Pipe** location to complete.  
**See Figure 9.**
11. Install remaining **Clamps** around pipes as shown in the opening diagram. Adjust **Tail Pipe** and Check along the whole length of the exhaust system all hardware and clamps, starting at the front and working rearward to secure the system. Check along the full length of the exhaust system to ensure there is adequate clearance for fuel lines, vent lines, brake lines, frame, bodywork, suspension, and any wiring, etc. If there is any interference detected, relocate, or adjust to provide adequate clearance.
12. Ensure all clamp connections are secure and components are unable to rotate or slide. Band clamps require approximately 45 lb-ft (60 Nm) of torque. Verify clearances, system security and band clamp torque after 30-60 miles (50-100 km) of driving.
13. Install and adjust the **Exhaust Tip** to suit.

**Congratulations!** You are ready to begin experiencing the improved power, sound and driving excitement of your **MBRP** Ltd. performance exhaust system. We know you will enjoy your purchase.

