

# S60200P

2001-2007 CHEV/GMC 2500/3500, EXTENDED CAB/CREW CAB, 6.6L DURAMAX,  
CAT-BACK, 5.0" SINGLE SIDE

# MBRP

4-Feb-21

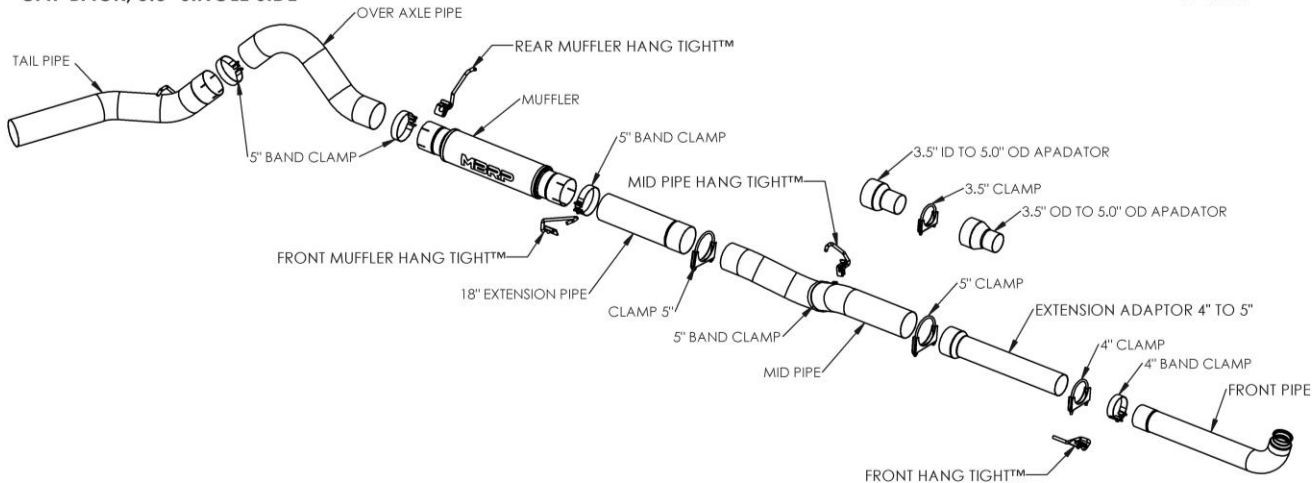

### PLEASE READ BEFORE STARTING INSTALLATION

MBRP Ltd. has made every effort to ensure that all components of this system are of superior quality and properly packaged. It is the installer's responsibility to ensure that all components are present and fit together as shown. Please also ensure that all components are undamaged before removal of the factory exhaust. Finally, check that this system properly matches the make and model of the vehicle and will not interfere with previous or planned modifications.

## Removal of Stock System:

1. Apply penetrating lubricant liberally to all exhaust fasteners, hangers and rubber insulators.
2. If vehicle is not equipped with a catalytic converter, proceed to step 3. If installing Cat Back system, for 01-05 cut front pipe 2.75" behind four bolt flange. Proceed to step 4. For 06-07 loosen the band clamp behind the catalytic converter. Proceed to step 4.
3. If the vehicle is not equipped with a catalytic converter disconnect the four bolt flange located approximately under the passenger seat.
4. Remove the exhaust system from the rubber insulators and remove from under the vehicle. If a hoist is not available for use it may be necessary to cut the tail pipe behind the muffler for removal of the system. If the vehicle is equipped with a catalytic converter, continue to Installation step 3.
5. Remove the spare tire. You may not be able to reinstall your spare tire after the installation of this exhaust system.

### **Steps 6&7 are for Down Pipe Back systems only**

6. Unbolt the OEM hanger from the transmission and remove. Do not discard the hanger as it is required for the installation.
7. Loosen the factory band clamp and remove the stock front pipe. Do not discard the band clamp as it is required for the installation.

## Installation of MBRP Performance Exhaust:

**Note: Vehicles originally equipped with a catalytic converter must retain the factory catalytic converter. Removal of the catalytic converter may be a violation of federal or local regulations.**

1. For Cat Back systems proceed to step 3. For 01-04 Downpipe-back systems install the **Front Pipe** onto the factory down pipe using the band clamp removed previously. Do not fully tighten to allow for adjustment.
2. Install the **Front Hang Tight™ Hanger** (see figure 1 for hanger clarification) onto a **4" Band Clamp** and the remaining **Hang Tight™ Hangers** onto **5" Band Clamps** using the procedure shown below (figure 2). (Hang Tight™ Hanger not exactly as shown).

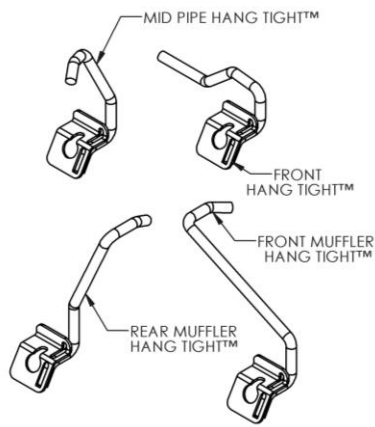

**Figure 1**

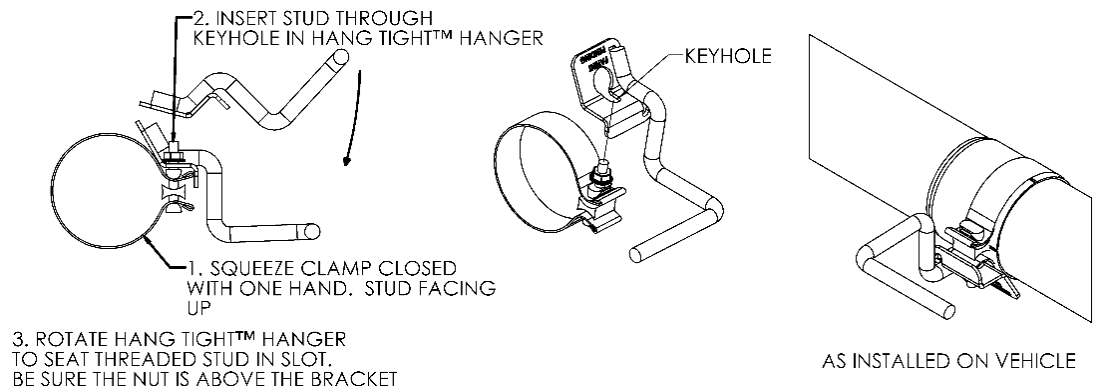

**Figure 2**

3. Install the hanger removed previously by sliding the outside hole in the rubber insulator over the **Front Hang Tight™** and re-connect to the transmission.
4. For 06-07 Cat Back systems only. Place the **3.5" OD to 5.0" ID Adaptor** provided into the factory band clamp located behind the catalytic converter.
5. For 01-05 Cat Back systems only. Place the **3.5" ID to 5.0" ID Adaptor** over the pipe behind the four bolt flange (cut in the stock removal steps). Secure it with the **3.5" Clamp** provided.
6. Install the **Extension Adaptor 4" to 5"** into the **Front Pipe** or **Adaptor**. For extended cab trucks, approximately 9½" needs to be cut off the longest straight end of the **Mid Pipe**. (**Installation tip:** Temporarily hang the **Muffler**, **Over-Axle Pipe**, and **Tail Pipe** in place and measure to the **Adaptor** to verify the length required).
7. Position the **Mid Pipe** bend around & under the cross member. Rotate the pipe to position the bend toward the driveshaft. Loosely install the **Mid Pipe Hang Tight™**. This will support the **Mid Pipe** during the **Muffler** installation.
8. Crew Cab & Extended Cab long box trucks require the use of the **18" Extension Pipe** provided. This is to be positioned between the **Muffler** and the **Mid Pipe**. Note: The **18" Extension Pipe** is not required with short box trucks.
9. Install the **Muffler** as shown on the **Extension Pipe** or **Mid Pipe** along with the **Front Muffler Hang Tight™**
10. Install the **Over-Axle Pipe** using the **Rear Muffler Hang Tight™** at the connection between the **Muffler** and the **Over-Axle Pipe** and into the OEM rubber hanger at this position.
11. Install the **5" Band Clamp** over the **Tail Pipe** and then install the **Tail Pipe** to the **Over-Axle Pipe**. Install the **Tail Pipe Hanger** into the OEM hanger, adjust for best axle clearance and **Tail Pipe** location to complete.
12. Tighten all hardware and clamps, starting at the front and working rearward to secure the system. Check along the full length of the exhaust system to ensure there is adequate clearance for fuel lines, vent lines, brake lines, frame, bodywork, suspension, and any wiring, etc. If there is any interference detected, relocate, or adjust to provide adequate clearance. Ensure all clamp connections are secure and components are unable to rotate or slide. Band clamps require approximately 45 lb-ft (60 N-m) of torque. Verify clearances, system security and band clamp torque after 30-60 miles (50-100 km) of driving.

**Congratulations!** You are ready to begin experiencing the improved power, sound and driving experience of your **MBRP** performance exhaust system. We know you will enjoy your purchase.