

S6100TD

94-02 DODGE CUMMINS, 2500/3500,
TURBO BACK, SINGLE

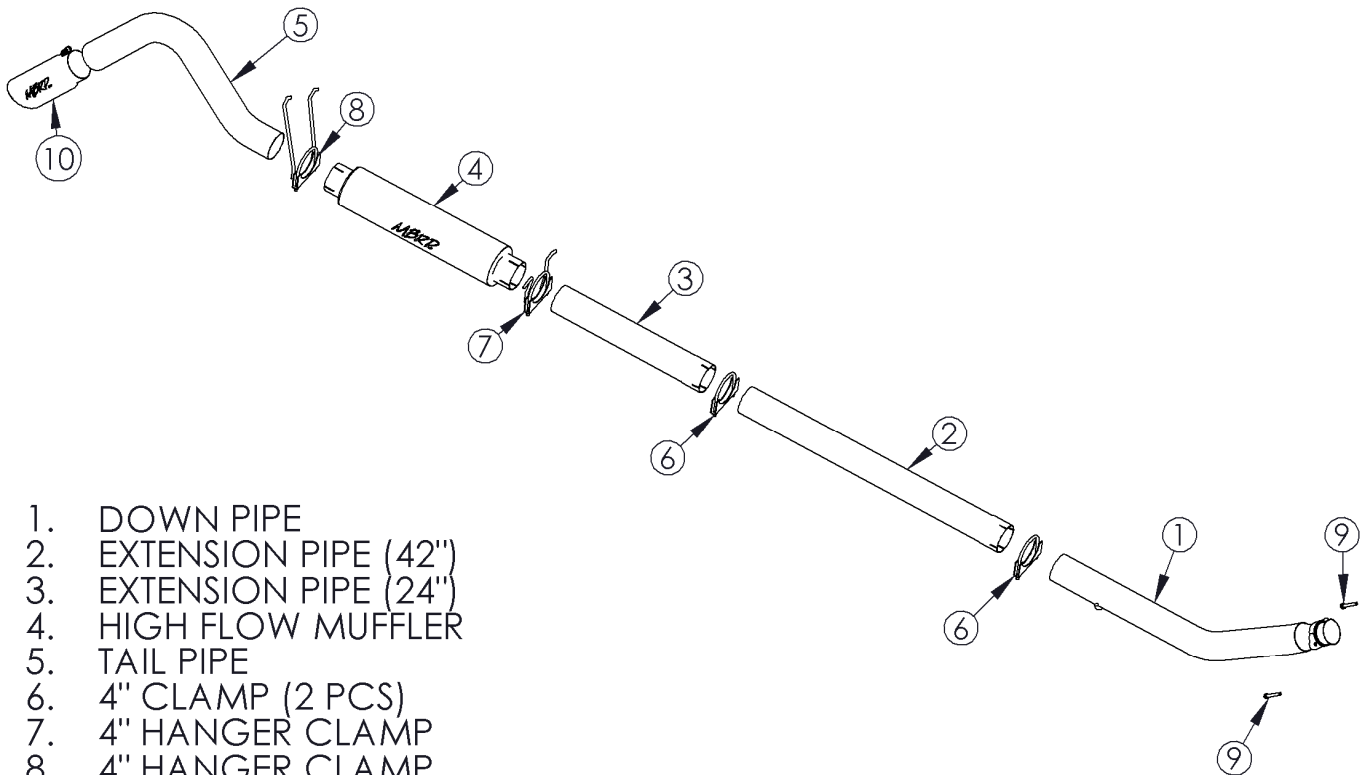

1. DOWN PIPE
2. EXTENSION PIPE (42")
3. EXTENSION PIPE (24")
4. HIGH FLOW MUFFLER
5. TAIL PIPE
6. 4" CLAMP (2 PCS)
7. 4" HANGER CLAMP
8. 4" HANGER CLAMP
9. M10 x 60mm BOLT (2 PCS)
10. EXHAUST TIP

PLEASE READ BEFORE STARTING INSTALLATION

While MBRP Inc. has made every effort to ensure that all components of this system are of superior quality and properly packaged, it is the installer's responsibility to ensure the following before removal of the factory exhaust:

- that ALL components shown above are present.
- that ALL mating components fit together.
- that there are no damaged components.
- that the system you have purchased is appropriate for your vehicle year, model and configuration.
- that the system will not interfere with any modifications previously installed or planned.
- that you have read and understand these instructions.

If you have any questions or are uncertain about any aspect of the installation of this system to your vehicle please contact your dealer before commencing installation.



Figure 1

Removal of Stock System:

1. Separate the stock exhaust system at the slip joint by the muffler. Remove the rear exhaust from the rubber hangers and remove the system from under the truck.
2. Using a 15mm socket or wrench, remove the two (2) bolts at the turbo flange and remove the stock down pipe.



Figure 2

Installation of MBRP Inc. Performance Exhaust:

Note: This exhaust is intended to be used on a lifted vehicle with the spare tire removed.

1. Install the **Down Pipe** starting from behind the cross member and place it in the same position as the stock down pipe. Place the hanger into the OEM rubber insulator and attaching the flared end to the turbo using the supplied **M10 x 60mm Bolts**. Do not fully tighten until all components are in place. **Refer to Figures 1 & 2.**
2. Install the **42" Extension Pipe** over the **Down Pipe**. The **42" Extension Pipe** may require cutting to accommodate vehicles other than the Quad Cab long bed. (**Installation tip:** Temporarily hang the **Muffler** and the **4" Hanger Clamp** in place using the two OEM rubber hangers and measure from the **Muffler** to the **Down Pipe** to determine the length required.) **Refer to Figure 3.**



Figure 3



Figure 4



Figure 5



Figure 6

3. Slide the **4" Hanger Clamp** over the inlet of the **Muffler**. Then install the **Muffler** over the **Extension Pipe** and place the **4" Hanger Clamp** into the OEM rubber hangers above the inlet. (Muffler orientation: Louver openings should face the rear of the vehicle). Refer to **Figures 4 & 5**.
4. Install the **Tail Pipe** from the rear of the truck, over the axle and attach to the outlet of the **Muffler** with **4" Hanger Clamp**. Now install the hangers into the OEM rubber hangers. Refer to **Figure 5**.
5. Install the remaining **Clamps** around the pipes where needed. Do not tighten the **Clamps** yet.
6. Install and adjust the **Exhaust Tip** to suit. Using a 17mm wrench tighten the lock bolt located on the **Exhaust Tip**. Refer to **Figure 6**.
7. Align the **Tail Pipe** and tighten the **Clamps** starting at the front and work rearward to secure the system.
8. Check along the full length of the exhaust to ensure there is adequate clearance for fuel lines, brake lines and any wiring, etc. If any interference is detected, relocate or adjust.

Congratulations! You are ready to begin experiencing the improved driving pleasure of your MBRP Inc. performance exhaust system. We know you will enjoy your purchase.