

S6108P

04.5-07 Dodge Cummins 600/610, 2500/3500, Cat Back

MBRP
INC.
PERFORMANCE EXHAUST
May 21, 2009

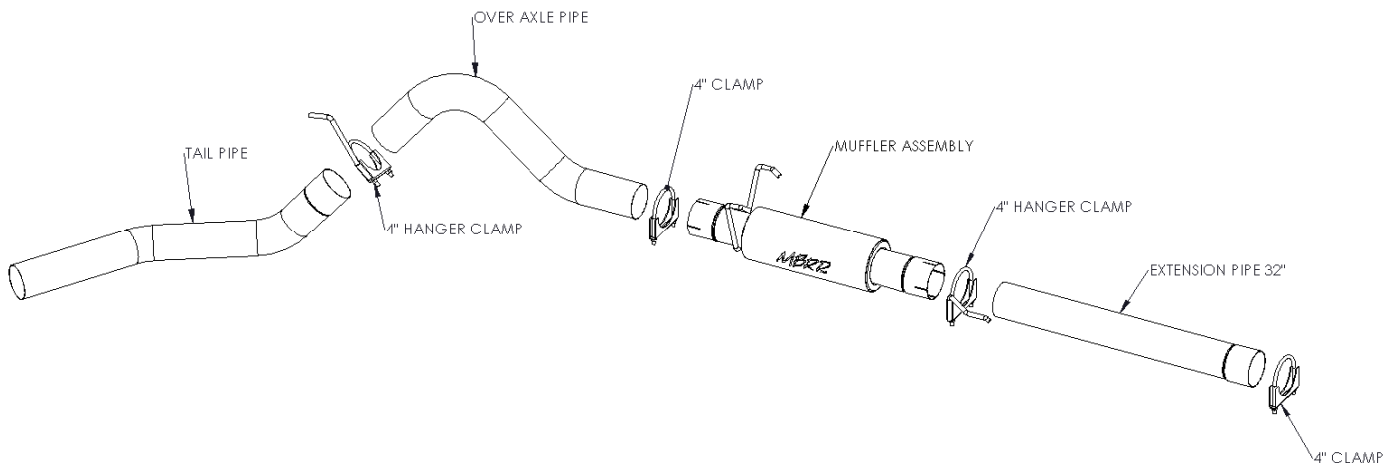

PLEASE READ BEFORE STARTING INSTALLATION

MBRP Inc. has made every effort to ensure that all components of this system are of superior quality and properly packaged. It is the installer's responsibility to ensure that all components are present and fit together as shown. Please also ensure that all components are undamaged before removal of the factory exhaust. Finally, check that this system properly matches the make and model of the vehicle and will not interfere with previous or planned modifications.

Removal of stock system:

1. Apply a penetrating lubricant liberally to all exhaust fasteners, hangers and rubber insulators.
2. Remove the exhaust system from the rubber insulators and remove all of the clamps from the catalytic converter reward.
3. Separate the slip joint behind the muffler and remove the tail pipe. Then separate the slip joint located behind the catalytic converter and remove the muffler and extension pipe.

Installation of MBRP Inc. Performance Exhaust:

1. Install the Extension Pipe onto the catalytic converter. The Extension Pipe will require cutting to accommodate vehicles other than the Quad Cab long bed or Mega Cab truck. (Installation tip: Temporarily hang the Muffler in place using the three OEM rubber hangers and measure from the Muffler to the catalytic converter to determine the length required.)
2. Install the Muffler over the Extension Pipe and into the OEM rubber hangers.
3. Install the 4" Hanger Clamp to the factory rubber insulator. Install the Tail Pipe and Over Axle Pipe from the rear of the truck, over the axle and attach to the outlet of the Muffler.
5. Install the provided Clamps around the pipes where required. Adjust the Tail Pipe and check along the whole length of the exhaust system to ensure there is adequate clearance around the fuel and brake lines or any wiring. If any interference is detected relocate or adjust.
6. Start at the front of the exhaust system and begin tightening all connections. Recheck for interference after tightening and adjust if required.

Congratulations! You are ready to begin experiencing the improved power, sound and driving excitement of your MBRP Inc. performance exhaust system. We know you will enjoy your purchase.