

# S61120

1998.5-2002 DODGE 2500/3500,  
5.9L CUMMINS, TURBO-BACK,  
5.0" SINGLE SIDE

# MBRP

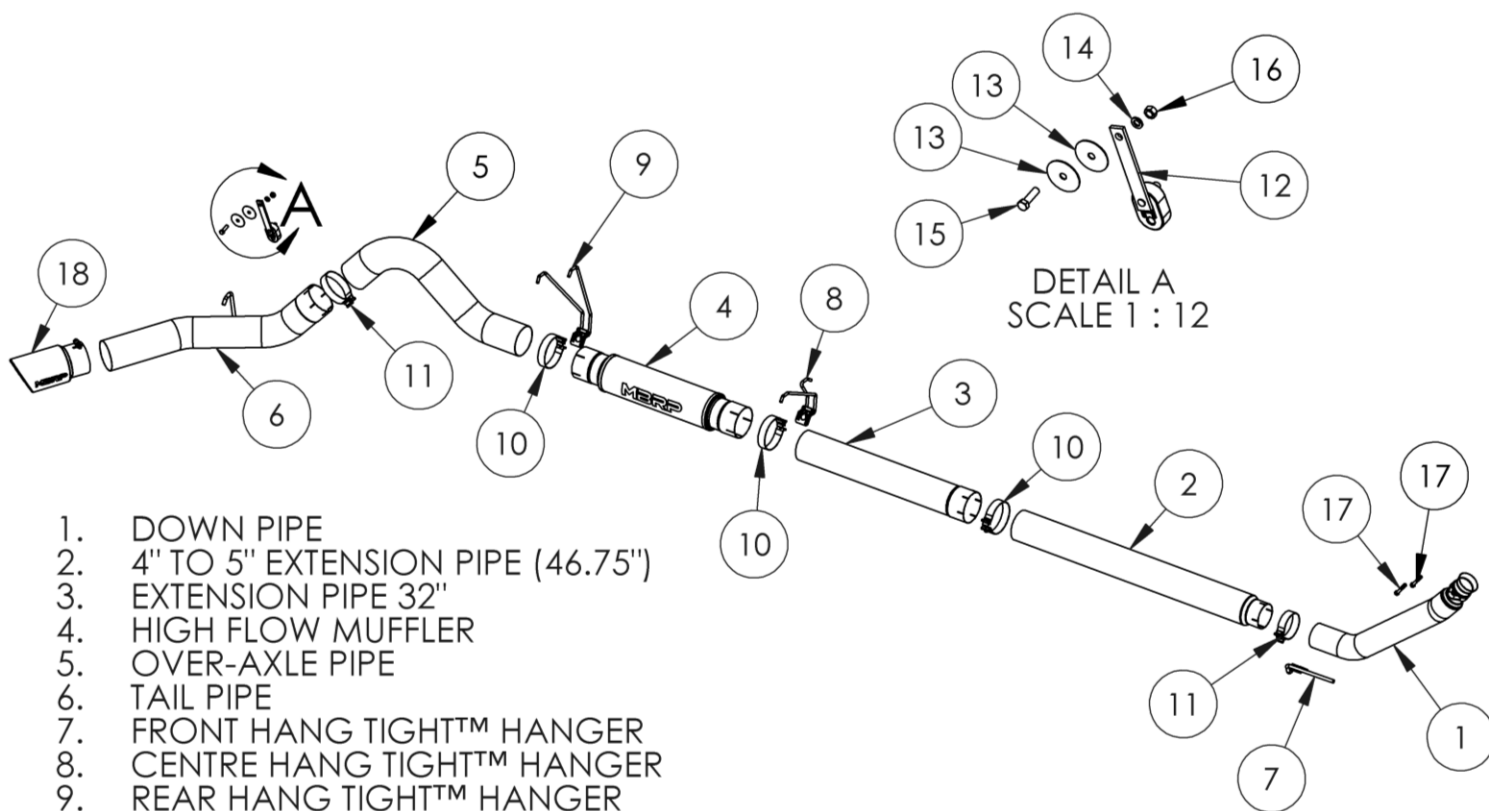

1. DOWN PIPE
2. 4" TO 5" EXTENSION PIPE (46.75")
3. EXTENSION PIPE 32"
4. HIGH FLOW MUFFLER
5. OVER-AXLE PIPE
6. TAIL PIPE
7. FRONT HANG TIGHT™ HANGER
8. CENTRE HANG TIGHT™ HANGER
9. REAR HANG TIGHT™ HANGER
10. 5" BAND CLAMP (4PCS)
11. 4" BAND CLAMP
12. HANGER ASSEMBLY
13. 7/16" FENDER WASHER (2 PCS)
14. 7/16" LOCK WASHER
15. 7/16" X 1 1/2" BOLT
16. 7/16" NUT
17. M10 -1.5 X 60MM BOLT (2 PCS)
18. EXHAUST TIP

## PLEASE READ BEFORE STARTING INSTALLATION

While MBRP Inc. has made every effort to ensure that all components of this system are of superior quality and properly packaged, it is the installer's responsibility to ensure the following before removal of the factory exhaust:

- that ALL components shown above are present.
- that ALL mating components fit together.
- that there are no damaged components.
- that the system you have purchased is appropriate for your vehicle year, model and configuration.
- that the system will not interfere with any modifications previously installed or planned.
- that you have read and understand these instructions.

If you have any questions or are uncertain about any aspect of the installation of this system to your vehicle please contact your dealer before commencing installation.

# MBRP

## Removal of stock system:

1. Separate the stock exhaust at the slip joint by the muffler. Remove the rear exhaust from the rubber hangers and remove the system from under the truck.
2. Using a socket or wrench, remove the two bolts at the turbo flange and remove the stock down pipe.
3. Remove the spare tire. You may not be able to reinstall your spare tire after the installation of this exhaust system.

## Installation of MBRP Performance Exhaust:

1. Install the **Down Pipe** in the same position as the stock down pipe and attach the flared end to the turbo using the supplied hardware. Do not fully tighten until all components are in place.
2. Install the **4" to 5" Extension Pipe (46.75")** over the **Down Pipe** securing it with the **4" Band Clamp** and **Front Hang Tight™ Hanger** (See figure 2 for Hang Tight™ instructions, Hang Tight™ hanger not exactly as shown). Install the **32" Extension Pipe** onto the **4" to 5" Extension Pipe** securing it with a **5" Band Clamp**. The combination of these two **Extension Pipes** provides the required length to fit a Quad Cab Long Bed truck, for Quad Cab Short Bed cut the **32" Extension Pipe** to 16" and for Regular Cab models cut down to 12".

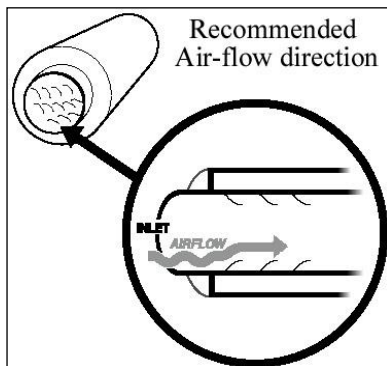

Figure 1

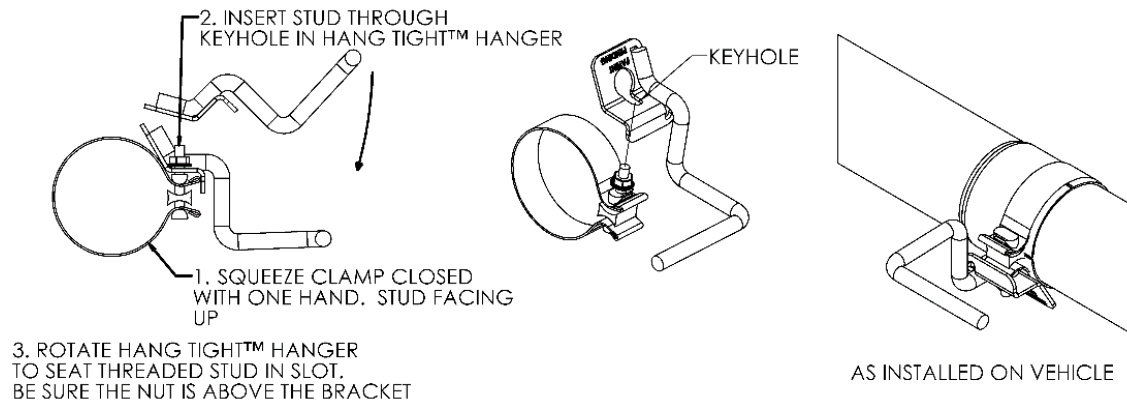

Figure 2

3. Install the **Muffler** over the required pipe securing it with the **Centre Hang Tight™ Hanger** so that the exhaust will flow smoothly over the louvers. **Refer to Figure 1.**
4. Install the **Rear Hang Tight™ Hanger** into the two OEM rubber hangers located above the outlet of the **Muffler**.
5. Remove the factory rubber insulator for the factory tail pipe. Install the **Over-Axle Pipe** and **5" Band Clamp** onto the **Tail Pipe**. From the rear of the truck, slide the assembly over the axle and attach to the outlet of the **Muffler**. Move the **Tail Pipe** into approximate position. Using the factory hole provided in the frame directly above the tail pipe hanger, attach the hanger provided (**HG002**) using the supplied hardware. Finish hanging the **Tail Pipe**.
6. Install and adjust the **Exhaust Tip** to suit. Tighten the lock bolt located on the **Exhaust Tip**.

# MBRP

7. Align the edge of band clamp with the edge of the joint it is connecting. Tighten all hardware and clamps, starting at the front and working rearward to secure the system. Check along the full length of the exhaust system to ensure there is adequate clearance for fuel lines, vent lines, brake lines, frame, bodywork, suspension, and any wiring, etc. If there is any interference detected, relocate, or adjust to provide adequate clearance. Ensure all clamp connections are secure and components are unable to rotate or slide. Band clamps require approximately 45 lb-ft (60 N-m) of torque. Verify clearances, system security and band clamp torque after 30-60 miles (50-100 km) of driving.

**Congratulations!** You are ready to begin enjoying the improved performance and driving experience of your **MBRP** performance exhaust system. We hope you enjoy your purchase.