

S6116TD

04.5-07 DODGE 5.9L CUMMINS
600/610, 2500/3500, 5" TURBO BACK,
SINGLE, OFF ROAD

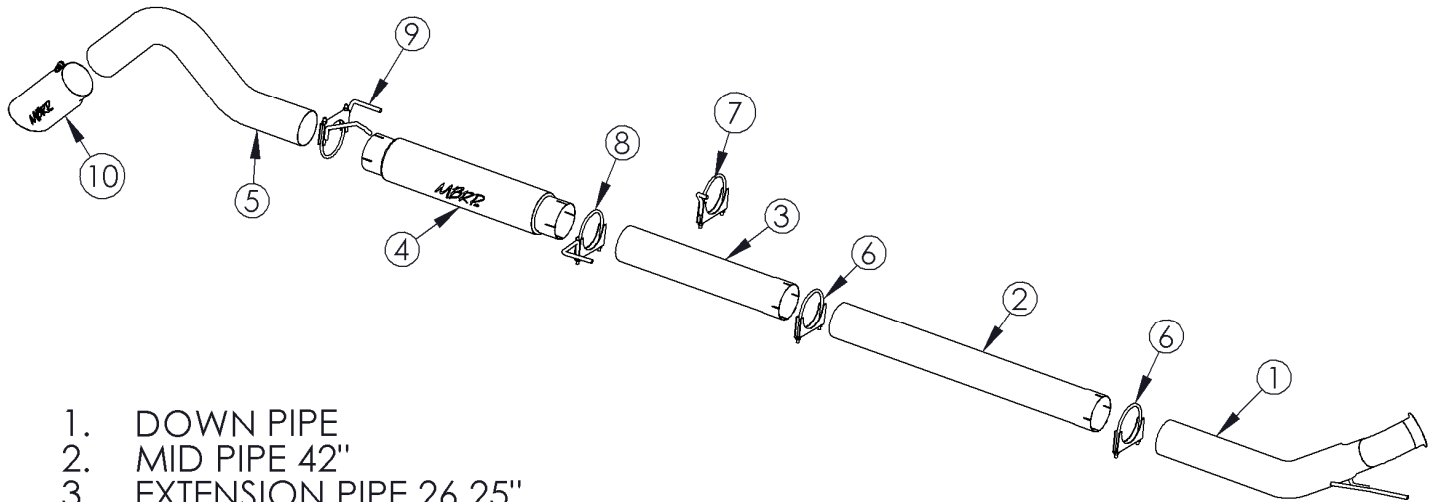

1. DOWN PIPE
2. MID PIPE 42"
3. EXTENSION PIPE 26.25"
4. HIGH FLOW MUFFLER
5. TAIL PIPE
6. 5" CLAMP (2PCS)
7. 5" HANGER CLAMP
8. 5" HANGER CLAMP
9. 5" HANGER CLAMP
10. EXHAUST TIP

PLEASE READ BEFORE STARTING INSTALLATION

While MBRP Inc. has made every effort to ensure that all components of this system are of superior quality and properly packaged, it is the installer's responsibility to ensure the following before removal of the factory exhaust:

- that ALL components shown above are present.
- that ALL mating components fit together.
- that there are no damaged components.
- that the system you have purchased is appropriate for your vehicle year, model and configuration.
- that the system will not interfere with any modifications previously installed or planned.
- that you have read and understand these instructions.

If you have any questions or are uncertain about any aspect of the installation of this system to your vehicle please contact your dealer before commencing installation.



Removal of Stock System:

1. Apply a penetrating lubricant liberally to all exhaust fasteners, hangers and rubber insulators.
2. Remove the exhaust system from the rubber insulators and remove all of the clamps from the system.
3. Separate the slip joint behind the muffler and remove the tail pipe. Next, separate the slip joint located behind the catalytic converter and remove the muffler and extension pipe. Remove the catalytic converter by separating the slip joint located between the down pipe and the catalytic converter. Now loosen the band clamp connecting the down pipe to the turbo and remove the down pipe. **Do not discard the band clamp as it is required for the installation.**
4. Remove the OEM down pipe hanger bracket from the bellhousing. **Do not discard these parts as they are required for the installation.**
5. Remove the spare tire. Remove the exhaust system from the vehicle.

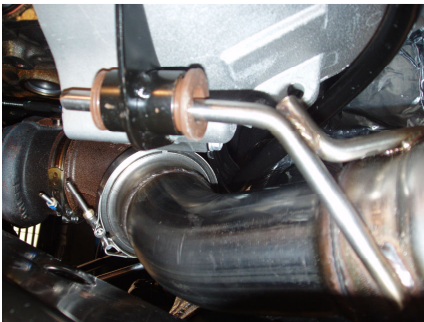

Figure 1

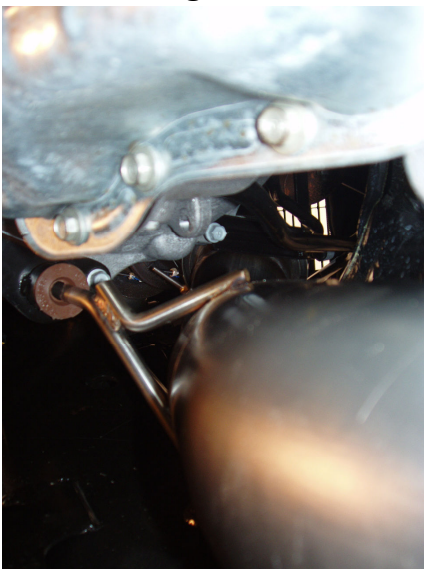

Figure 2

Installation of MBRP Inc. Performance Exhaust:

Note: This exhaust is intended to be used on a lifted vehicle with the spare tire removed.

1. Slide the OEM down pipe hanger bracket onto the **Down Pipe** hanger. Install the **Down Pipe** in the same position as the stock down pipe by reattaching the hanger bracket to the bellhousing and then attaching the flared end to the turbo using the stock band clamp. Do not fully tighten until all components are in place. **Refer to Figure 1 & 2.**

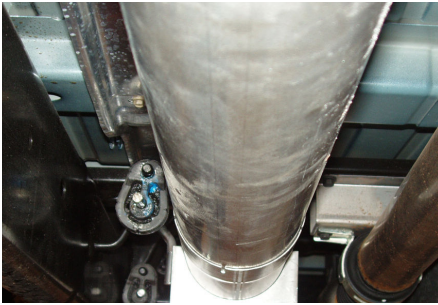

Figure 3

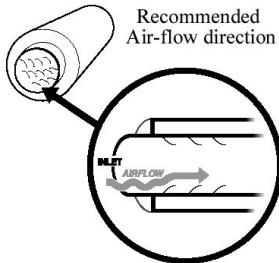

Figure 4



Figure 5



Figure 6



Figure 7

2. Install the **Mid Pipe** onto the **Down Pipe** and then the **Extension Pipe** onto the **Mid Pipe**. The combination of the **Mid Pipe** and **Extension Pipe** provides the required length to fit a Quad Cab Long Bed truck or Mega Cab. These pipes will have to be cut to fit all other vehicles. **Installation Tip:** Temporarily install the **Muffler** and **Tail Pipe** using the factory rubber insulators and the **5" Hanger Clamps** (8) & (9). **Refer to Illustration.** Measure from the **Muffler** to the **Mid Pipe** to determine the length required. Cut the pipe to the required length. **Refer to Figure 3.**
3. Install the **Muffler** over the required pipe so that the exhaust will flow smoothly over the louvers. Refer to the illustration on the left. **Refer to Figure 4.**
4. Install the **Hanger Clamp** into the OEM rubber hanger located on the frame near the inlet of the **Muffler**. **Refer to Figure 5.**
5. Install the **5" Hanger Clamp** into the two OEM rubber hangers located above the outlet of the **Muffler**. **Refer to Figure 6.**
6. Install the **Tail Pipe** from the rear of the truck, over the axle and attach to the outlet of the **Muffler**. Install provided clamps around pipes where needed.
7. Adjust **Tail Pipe** and check along the whole length of the exhaust system to ensure there is adequate clearance around the fuel and brake lines or any wiring. If any interference is detected relocate or adjust. Start at the front of the exhaust system and begin tightening all connections.
8. Install and adjust the **Exhaust Tip** to suit. Using a 17mm wrench tighten the lock bolt located on the **Exhaust Tip**.

Congratulations! You are ready to begin experiencing the improved driving pleasure of your MBRP Inc. performance exhaust system. We know you will enjoy your purchase.