

S6120TD

07-09 DODGE CUMMINS 6.7L 2500/3500,
PARTICULATE FILTER BACK

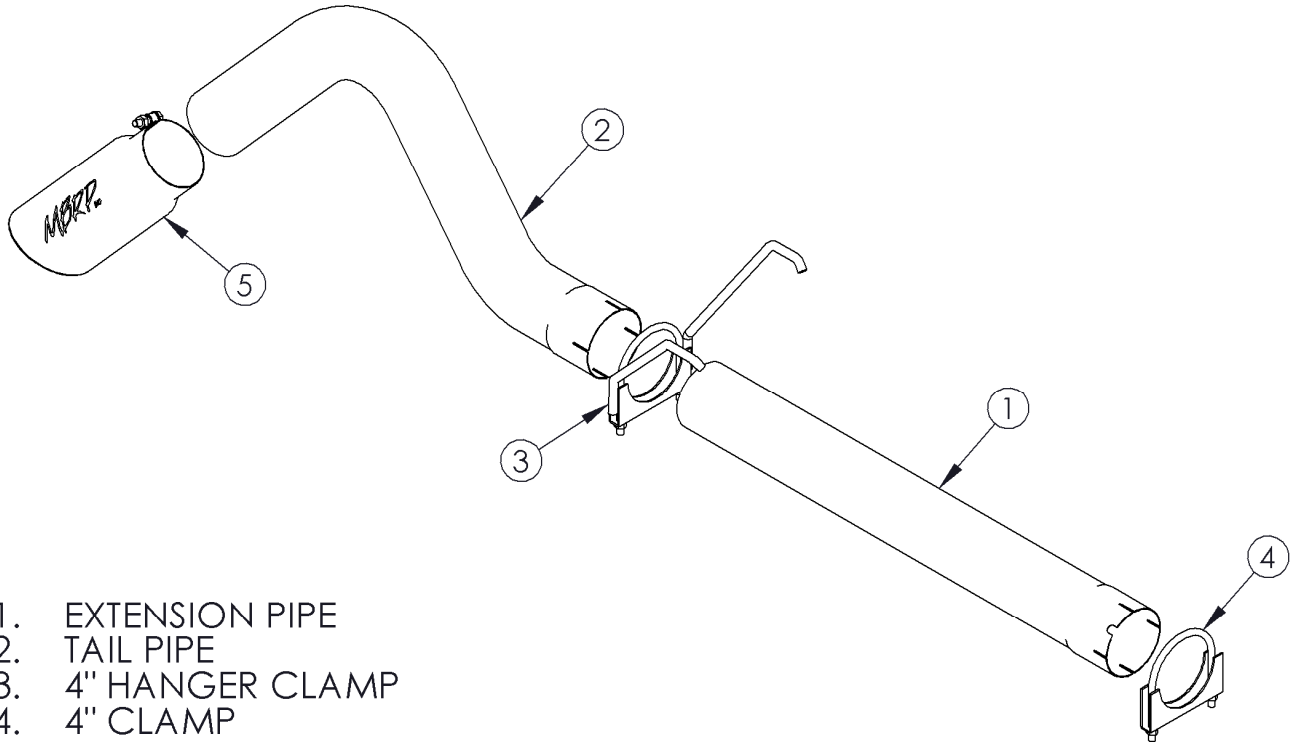

1. EXTENSION PIPE
2. TAIL PIPE
3. 4" HANGER CLAMP
4. 4" CLAMP
5. EXHAUST TIP

PLEASE READ BEFORE STARTING INSTALLATION

While MBRP Inc. has made every effort to ensure that all components of this system are of superior quality and properly packaged, it is the installer's responsibility to ensure the following before removal of the factory exhaust:

- that ALL components shown above are present.
- that ALL mating components fit together.
- that there are no damaged components.
- that the system you have purchased is appropriate for your vehicle year, model and configuration.
- that the system will not interfere with any modifications previously installed or planned.
- that you have read and understand these instructions.

If you have any questions or are uncertain about any aspect of the installation of this system to your vehicle please contact your dealer before commencing installation.



Removal of Stock System:

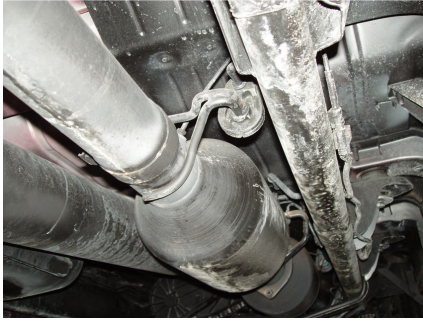

Figure 1

1. Apply a penetrating lubricant liberally to all exhaust fasteners, hangers and rubber insulators.

2. Loosen the nut on the clamps located behind the particulate filter and behind the muffler using a 15mm wrench or socket. **Refer to Figure 1.**

3. Remove the muffler and tail pipe from the OEM rubber hangers. Remove the stock exhaust from vehicle. **Refer to Figure 2.**



Figure 2

Installation of MBRP Inc. Performance Exhaust:

1. The **Extension Pipe** provided fits the Mega Cab short box (76.3" box) or the Quad Cab long bed (98.3" box) without cutting. Slide a **4" Clamp** onto the **Extension Pipe**. **Refer to Figure 3.** For the Quad Cab short box (76.3" box) the **Extension Pipe** must be cut. **Refer to Figure 4.**



Figure 3

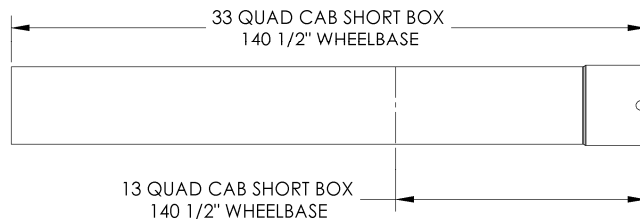

Figure 4



Figure 5

2. Slide the **4" Hanger Clamp** onto the end of the **Extension Pipe**. Install the hangers into the existing OEM rubber insulators. **Refer to Figure 5.**



Figure 6

3. Install the **Tail Pipe** from the rear of the truck, over the axle and attach to the **Extension Pipe** using the **4" Hanger Clamp**. **Refer to Figure 6.**

4. Install and adjust the **Exhaust Tip** to suit. Using a 17mm wrench, tighten the lock bolt located on the **Exhaust Tip**. **Refer to Figure 7.**

5. Align the exhaust as required. Starting at the front of the exhaust, tighten all clamps and connections.



Figure 7

6. Check along the whole length of the exhaust system to ensure that there is adequate clearance around the spare tire, fuel and brake lines or any wiring. If any interference is detected relocate or adjust.

Congratulations! You are ready to begin experiencing the improved power, sound and driving experience of your MBRP Inc. performance exhaust system. We are certain that you will enjoy your purchase.