

S8110

'04.5-'07.5, 5.9L, CAT BACK
'07.5-'09, 6.7L, PARTICULATE FILTER BACK
(MC/SB ONLY) SMOKERS™ SINGLE

MBRP INC.

PERFORMANCE EXHAUST

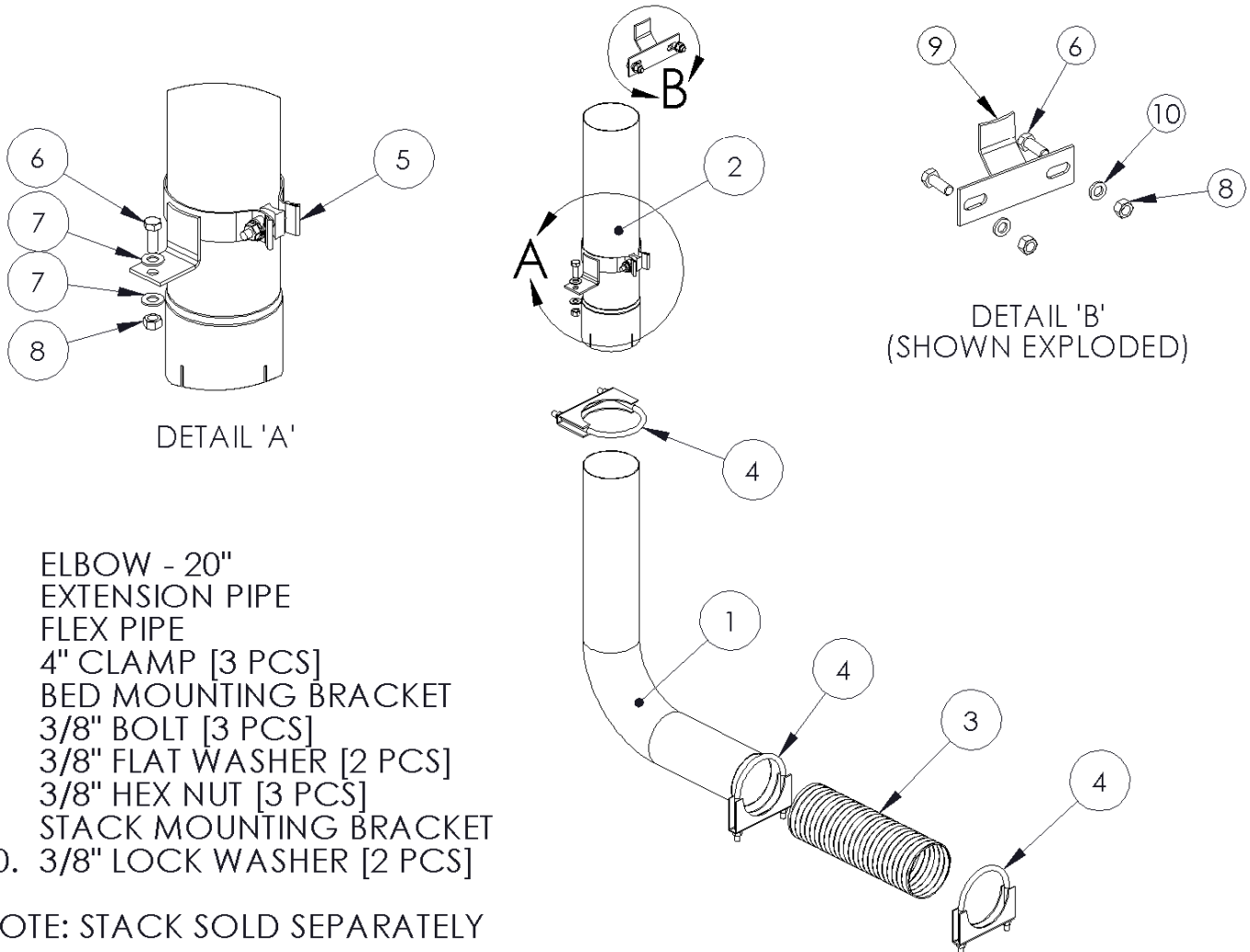

PLEASE READ BEFORE STARTING INSTALLATION

While MBRP Inc. has made every effort to ensure that all components of this system are of superior quality and properly packaged it is the installer's responsibility to ensure the following before removal of the factory exhaust:

- that ALL components shown above are present.
- that ALL mating components fit together.
- that there are no damaged components.
- that the system you have purchased is appropriate for your vehicle year, model and configuration.
- that the system will not interfere with any modifications previously installed or planned.
- that you have read and understand these instructions.

If you have any questions or are uncertain about any aspect of the installation of this system to your vehicle please contact your dealer before commencing installation.

Removal of Stock System:

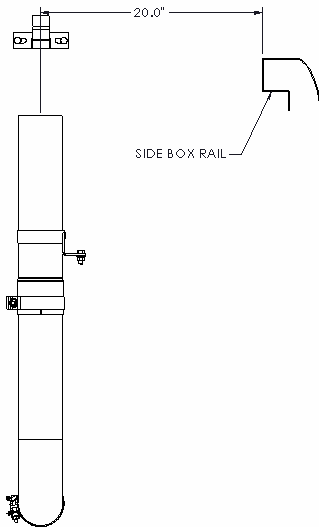

Figure 1

1. Apply a penetrating lubricant liberally to all exhaust fasteners, hangers and rubber insulators.
2. Loosen the factory band clamps located behind the Catalytic Converter (on the 5.9L) or the Diesel Particulate Filter (DPF – on the 6.7L) followed by the slip joints before and after the muffler.
3. Remove the muffler and tail pipe from the OEM rubber hangers. Separate the stock exhaust system at the slip joints. Remove the muffler and tail pipe from under the truck.

Installation of MBRP Inc. "Smokers™"



Figure 2



Figure 3



Figure 4

1. Measure 20" across from the inside surface of the passenger side bed rail. This will be the centerline of the **Stack** once installed. Ensure that your measurements are accurate. Mark this location along the bed rail. **Refer to Figure 1.**
2. Slide the **Band Clamp** (from **Stack** kit – purchased separately) over the **Stack**. Wedge the **Stack Mounting Bracket** between the **Band Clamp** and the **Stack**. Adjust to the bed rail height and tighten the **Band Clamp** slightly. Make sure the **Stack** is vertical and the **Stack Mounting Bracket** is flush against the bed rail and centered on the measurement made in Step 1. Trace a circle around the base of the **Stack** and center punch the circle's center. **Verify that the center punch hole is in line with your existing exhaust and adjust accordingly.** This will be the center line of your **Stack**.
3. Align the **Stack** centered on the mark you made in Step 2. Mark the bolt hole location of the **Stack Mounting Bracket** onto the front rail of the bed. Center punch the marks and drill holes to accommodate the 3/8" hardware. **Refer to Figure 2.**
4. Loosely attach the **Stack Mounting Bracket** to the front of the truck bed using the 3/8" hardware supplied. Set the **Stack** up in the bed and loosely attach it to the **Stack Mounting Bracket**. Make sure the **Stack** is vertical and in the desired position. **Refer to Figure 3.**
5. Confirm the base of the **Stack** is resting in the same position as in Step 2. Re-trace and center punch if needed. This is where the **Extension Pipe** will pass through the floor. Remove the **Stack** from the bed of the truck. Drill the hole using a 5" hole saw. It may be required to cut part of a bed floor rail away. **Refer to Figure 4.**



Figure 5

6. Install the **Flex Pipe** on the outlet of the Catalytic Converter or DPF depending on the model year of your truck. Place the **20" Elbow** in position and mark the locations to cut. Allow 3" of overlap at the **Flex Pipe** and **20" Elbow** connections. Cut the **20" Elbow** to the required length and install. Remember to slide the required **Clamps** onto the parts before assembly. **Refer to Figure 5.**
7. Slide the **Bed Mounting Bracket** onto the **Extension Pipe**. Install the assembly on the outlet of the **20" Elbow** with the required **Clamp**. Reinstall the **Stack** by sliding the inlet over the **Extension Pipe** and then securing the **Stack** to the **Stack Mounting Bracket** with the **Clamp** supplied with your **Stack**. Align the system and tighten all **Clamps** to ensure your "**Smokers™**"

exhaust remains properly aligned.

8. Slide the **Bed Mounting Bracket** to the desired position on the **Extension Pipe** to allow installation of the mounting hardware. Ensure the **Stack** is aligned vertically. Trace the **Bed Mounting Bracket** hole from the bracket onto the bed floor and drill a hole to accommodate the **3/8"** hardware supplied. Secure the **Bed Mounting Bracket** to the truck and tighten the **Clamp** to the **Extension Pipe**. The **Bed Mounting Bracket** will ensure the **Stack** remains in position and doesn't vibrate.
9. Check along the whole length of the exhaust system to ensure that there is adequate clearance around fuel lines, brake lines and any wiring. If any interference is detected relocate or adjust.



Congratulations! You are ready to begin experiencing the improved power, sound and driving experience of your MBRP Inc. "**Smokers™**". We are certain you will enjoy your purchase.