

S8114

**'03-'04 DODGE CUMMINS, TURBO BACK,
SMOKERS™ SINGLE**

MBRP
INC.

PERFORMANCE EXHAUST

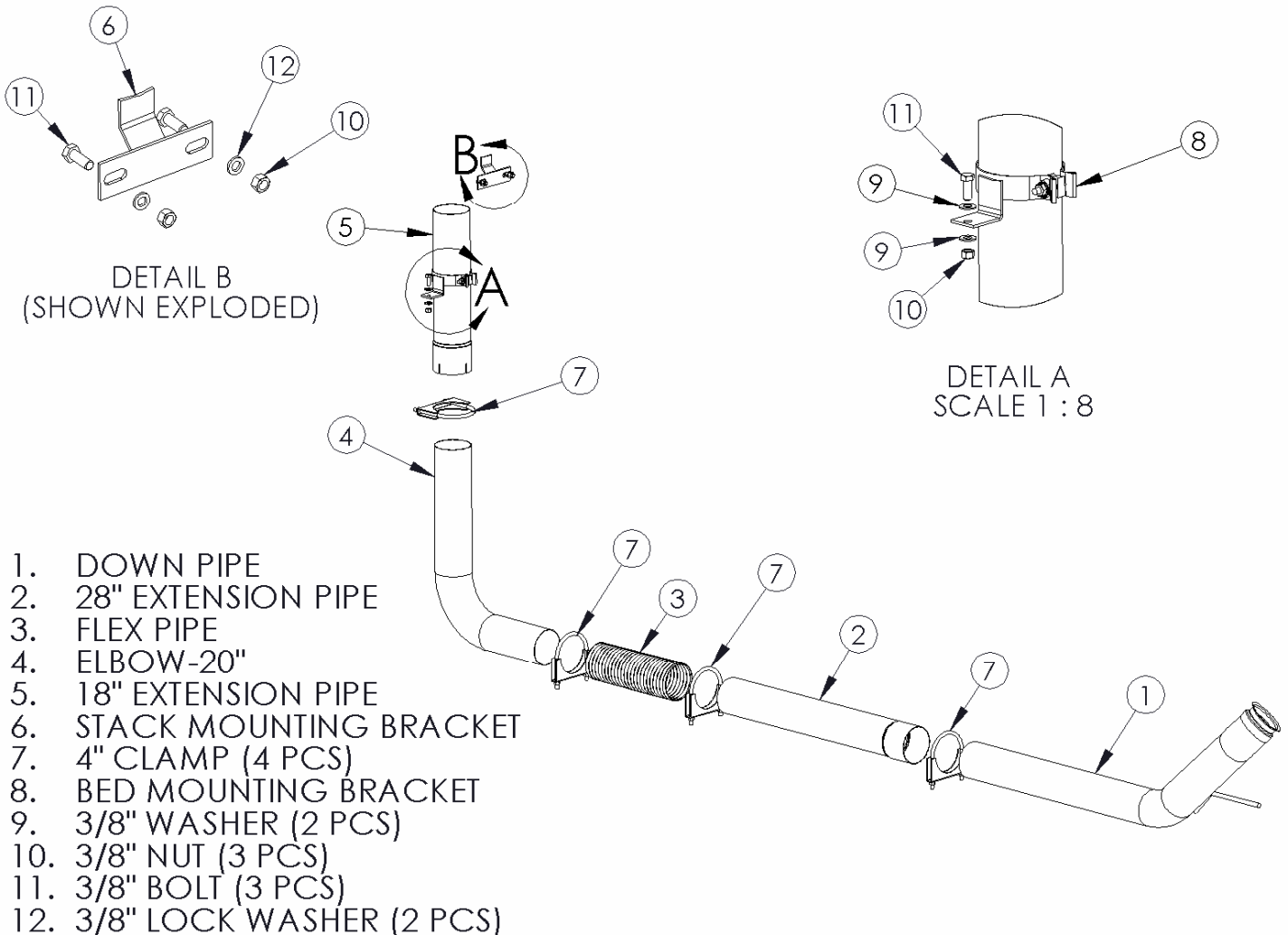

NOTE: STACK SOLD SEPARATELY

PLEASE READ BEFORE STARTING INSTALLATION

While MBRP Inc. has made every effort to ensure that all components of this system are of superior quality and properly packaged it is the installer's responsibility to ensure the following before removal of the factory exhaust:

- that ALL components shown above are present.
- that ALL mating components fit together.
- that there are no damaged components.
- that the system you have purchased is appropriate for your vehicle year, model and configuration.
- that the system will not interfere with any modifications previously installed or planned.
- that you have read and understand these instructions.

If you have any questions or are uncertain about any aspect of the installation of this system to your vehicle please contact your dealer before commencing installation.

Removal of Stock System:

1. Apply a penetrating lubricant liberally to all exhaust fasteners, hangers and rubber insulators.
2. Remove the exhaust system from the rubber insulators and remove all of the clamps from the system.
3. Separate the slip joint behind the Muffler and remove the Tail Pipe. Next, separate the slip joint connecting the Down Pipe and the extension pipe to remove the Muffler and Extension Pipe. Next loosen the Band Clamp connecting the Down Pipe to the turbo and remove the Down Pipe. **Do not discard the band clamp as it is required for the installation.**

Installation of MBRP Inc. "Smokers™":

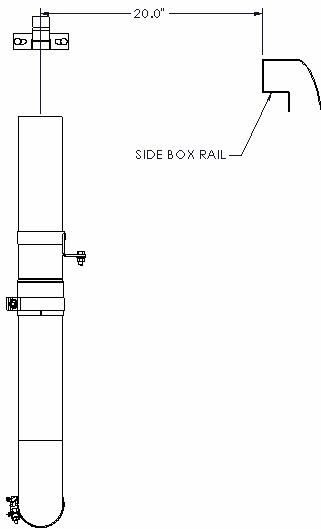

Figure 1



Figure 2

1. Install the **Down Pipe** in the same position as the stock Down Pipe by sliding the hanger into the OEM hanger bracket and then attaching the flared end to the turbo using the stock Band Clamp. Do not fully tighten until all components are in place.
2. Loosely install the **28" Extension Pipe** over the **Down Pipe**. The **28" Extension Pipe** may require cutting to accommodate vehicles other than the Quad Cab Long Bed.
3. Measure 20" across from the inside surface of the passenger side bed rail. Mark this location along the rail. This will be the approximate centerline of the **Stack** once installed. **Refer to Figure 1.**
4. Slide the **Band Clamp** (from **Stack** kit – purchased separately) over the **Stack**. Wedge the **Stack Mounting Bracket** between the **Band Clamp** and **Stack**. Adjust to the bed rail height and tighten the **Band Clamp** slightly. Make sure the **Stack** is vertical and the **Stack Mounting Bracket** is flush against the bed rail and centered on the mark you made in Step 3. Trace a circle around the base of the **Stack** and center punch the circle's center. **Verify that the center punch hole is in line with the 28" Extension Pipe and adjust accordingly.** This will be the center line of your **Stack**.
5. Align the **Stack** centered on the mark you made in Step 4. Mark the bolt hole location of the **Stack Mounting Bracket** onto the front rail of the bed. Center punch the marks and drill holes to accommodate the **3/8"** hardware. **Refer to Figure 2.**

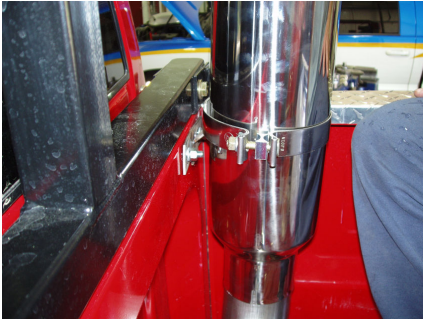

Figure 3

6. Loosely attach the **Stack Mounting Bracket** to the front of the truck bed using the **3/8"** hardware supplied. Set the **Stack** up in the bed and loosely attach it to the **Stack Mounting Bracket**. Make sure the **Stack** is vertical and in the desired position. **Refer to Figure 3.**



Figure 4

7. Confirm the base of the **Stack** is resting in the same position as in Step 4. Re-trace and center punch if needed. This is where the **18" Extension Pipe** will pass through the floor. Remove the **Stack** from the bed of the truck. Drill a hole using a **5" saw**. It may be required to cut a part of a bed floor rail away. **Refer to Figure 4.**



Figure 5

8. Measure from the **18" Extension Pipe** slip joint to the **28" Extension Pipe**. Mark and cut the shorter side of the **20" Elbow** to the required length so that it lines up with the **28" Extension Pipe**. Cut the **28" Extension Pipe** in a place where the **Flex Pipe** can be placed between the exhaust system and the **20" Elbow**. It may be necessary to cut the **20" Elbow** again as well as the **Flex Pipe** to ensure proper fit. **Refer to Figure 5.**



Figure 6

9. Attach the **20" Elbow** to the **18" Extension Pipe** slip joint and then attach the **Flex Pipe** to both the **20" Elbow** and the **28" Extension Pipe**. Be sure to slide the required **Clamps** over the **20" Elbow** and **Flex Pipe** before connecting it to the **28" Extension Pipe**. **Refer to Figure 6.**



10. Slide the **Bed Mounting Bracket** onto the **18" Extension Pipe**. Install the assembly on the outlet of the **20" Elbow** with the required **Clamp**. Reinstall the **Stack** by sliding the inlet over the **18" Extension Pipe** and then securing the **Stack** to the **Mounting Bracket** with the **Clamp** supplied with your **Stack**. Align the system and tighten all **Clamps** to ensure that your "Smokers™" exhaust system remains properly aligned.
11. Slide the **Bed Mounting Bracket** to the desired position on the **18" Extension Pipe** to allow installation of the mounting hardware. Ensure the **Stack** is vertical. Trace the **Bed Mounting Bracket** hole from the bracket to the bed floor and drill a hole to accommodate the **3/8"** hardware supplied. Secure the **Bed Mounting Bracket** to the truck and tighten the **Clamp** to the **18" Extension Pipe**. This **Clamp** will ensure the **Stack** remains in position and doesn't vibrate.
12. Check along the whole length of the exhaust system to ensure that there is adequate clearance around fuel lines, brake lines and any wiring. If any interference is detected, relocate or adjust.



Congratulations! You are ready to begin experiencing the improved power, sound and driving excitement of your MBRP Inc. "Smokers™". We are certain that you will enjoy your purchase.