

S8116

**94-02 DODGE CUMMINS, TURBO BACK
SMOKERS 5"™**

MBRP
INC.

PERFORMANCE EXHAUST

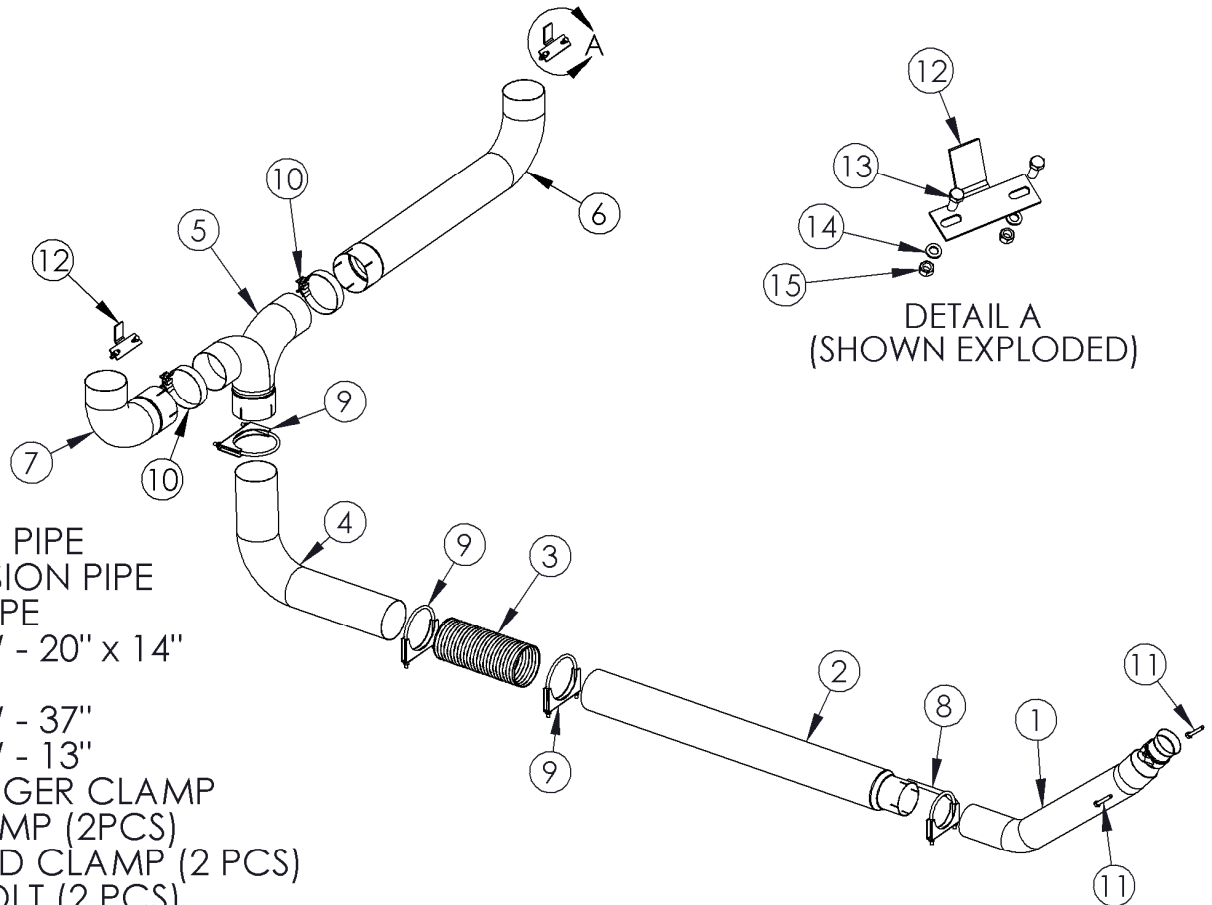

1. DOWN PIPE
2. EXTENSION PIPE
3. FLEX PIPE
4. ELBOW - 20" x 14"
5. T-PIPE
6. ELBOW - 37"
7. ELBOW - 13"
8. 4" HANGER CLAMP
9. 5" CLAMP (2PCS)
10. 5" BAND CLAMP (2 PCS)
11. HEX BOLT (2 PCS)
12. SMOKER MOUNTING BRACKET (2PCS)
13. 3/8 HEX BOLT (4PCS)
14. 3/8 LOCK WASHER (4PCS)
15. 3/8 HEX NUT (4PCS)

NOTE: STACKS SOLD SEPARATELY

PLEASE READ BEFORE STARTING INSTALLATION

While MBRP Inc. has made every effort to ensure that all components of this system are of superior quality and properly packaged it is the installer's responsibility to ensure the following before removal of the factory exhaust:

- that ALL components shown above are present.
- that ALL mating components fit together.
- that there are no damaged components.
- that the system you have purchased is appropriate for your vehicle year, model and configuration.
- that the system will not interfere with any modifications previously installed or planned.
- that you have read and understand these instructions.

If you have any questions or are uncertain about any aspect of the installation of this system to your vehicle please contact your dealer before commencing installation.



Figure 1

Removal of Stock System:

1. Separate the stock exhaust system at the slip joint by the muffler. Remove the rear exhaust from the rubber hangers and remove the system from under the truck.
2. Using a 15mm socket or wrench, remove the (2) bolts at the turbo flange and remove the stock down pipe.



Figure 2

Installation of MBRP Inc. "Smokers":

1. Install the **Down Pipe** in the same position as the stock down pipe placing the hanger into the OEM rubber insulator and attaching the flared end to the turbo using the supplied hardware. Do not fully tighten until all components are in place. **Refer to Figure 1.**
2. Loosely install the **Extension Pipe** over the **Down Pipe**. The **Extension Pipe** may require cutting to accommodate vehicles other than the Quad Cab long box. **Refer to Figure 2.**
3. Loosely assemble the in bed portion of the **T-Pipe Assembly (T-Pipe, 13" Elbow and 37" Elbow)**. Some models may require trimming of the **T-Pipe** in order to accommodate the width of the truck bed and the **Stacks** that have been purchased separately. Be sure to place the **Clamps** over the pieces before they are assembled.
4. Place the **Stacks** onto the **T-Pipe Assembly** and position into the desired position in the truck bed. The **37" Elbow** should be on the driver side so that the **T-Pipe** passes through the bed floor towards the passenger side. **Refer to Figure 3.**
5. Place the **Mounting Brackets** between each **Stack** and the front of the truck bed so that the **Stacks** are properly spaced from the front of the truck bed. Center the **Mounting Brackets** on the **Stacks** and mark the front of the truck bed in the center of the slotted holes in the **Mounting Brackets**. Center punch the marks and drill holes to accommodate a **3/8" Bolt** (included with the **Mounting Brackets**). **Refer to Figure 4.**



Figure 3



Figure 4



Figure 5



Figure 6



Figure 7



Figure 8



Figure 9

6. Loosely attach the **Mounting Brackets** to the front of the truck bed using the 3/8" hardware supplied. Set the **Stacks** up in the bed and loosely attach them to the **Mounting Brackets**. Make sure the **Stacks** are in the desired position and the **T-Pipe Assembly** is level.
7. Mark the bed floor where the **T-Pipe** is resting. MBRP Inc. recommends tracing around where the **T-Pipe** meets the bed floor. **Refer to Figure 5**. Remove **Stacks** and **T-Pipe Assembly** from the bed of the truck. Find the center of the circle traced onto the bed floor, mark and center punch it. Go under the vehicle and locate the center punch mark. This marks the location where you are going to cut a hole for the **T-Pipe** to pass through the bed of the truck. If you cannot find the center punch mark use a small drill to create a pilot hole. Make sure that there is clearance for the **14" Elbow** to pass by any frame cross members. Remove or modify any heat shields that may cause interference.
8. Cut a hole through the truck bed providing adequate clearance around the part of the **T-Pipe** that passes through the truck bed. MBRP Inc. recommends using a 6" diameter hole saw. It may be required to cut away part of a bed rail. **Refer to Figure 6**.
9. Set the **T-Pipe Assembly** at the desired height from the floor of the bed (This will set the height of the **Stacks**). Using spacers to hold the **T-Pipe Assembly** at the desired height, loosely attach the **Stacks** to the **Mounting Brackets** making sure that they are straight. This will hold the assembly steady while you line up to the exhaust under the vehicle. **Refer to Figure 7**.
10. Measure from the **T-Pipe** slip joint to the **Extension Pipe**. Mark and cut the shorter side of the **14" Elbow** to the required length so that it lines up with the front part of the exhaust system. **Refer to Figure 8**.
11. Attach the **14" Elbow** to the **T-Pipe** slip joint and then attach the **Flex Pipe** to both the **14" Elbow** and the **Extension Pipe**. Be sure to slide the required **Clamps** over the **14" Elbow** and **Flex Pipe** before connecting it then to the **Extension Pipe**. **Refer to Figure 9**.
12. Make sure that the **Mounting Brackets** are centered on the **Stacks** and tighten the fasteners holding the **Mounting Brackets** to the front of the truck bed. Tighten all **Clamps** making sure that the **Stacks** remain properly aligned.

MBRP
INC.
PERFORMANCE EXHAUST



System shown in pictures is 4" with 36" Stacks (B1410)

Congratulations! You are ready to begin experiencing the improved power, sound and driving excitement of your MBRP Inc. *"Smokers"*: We are certain you will enjoy your purchase.