

**S8206**

'99-'03 FORD POWER STROKE 7.3L, TURBO  
BACK, SMOKERS™ SINGLE

**MBRP**  
INC.

**PERFORMANCE EXHAUST**

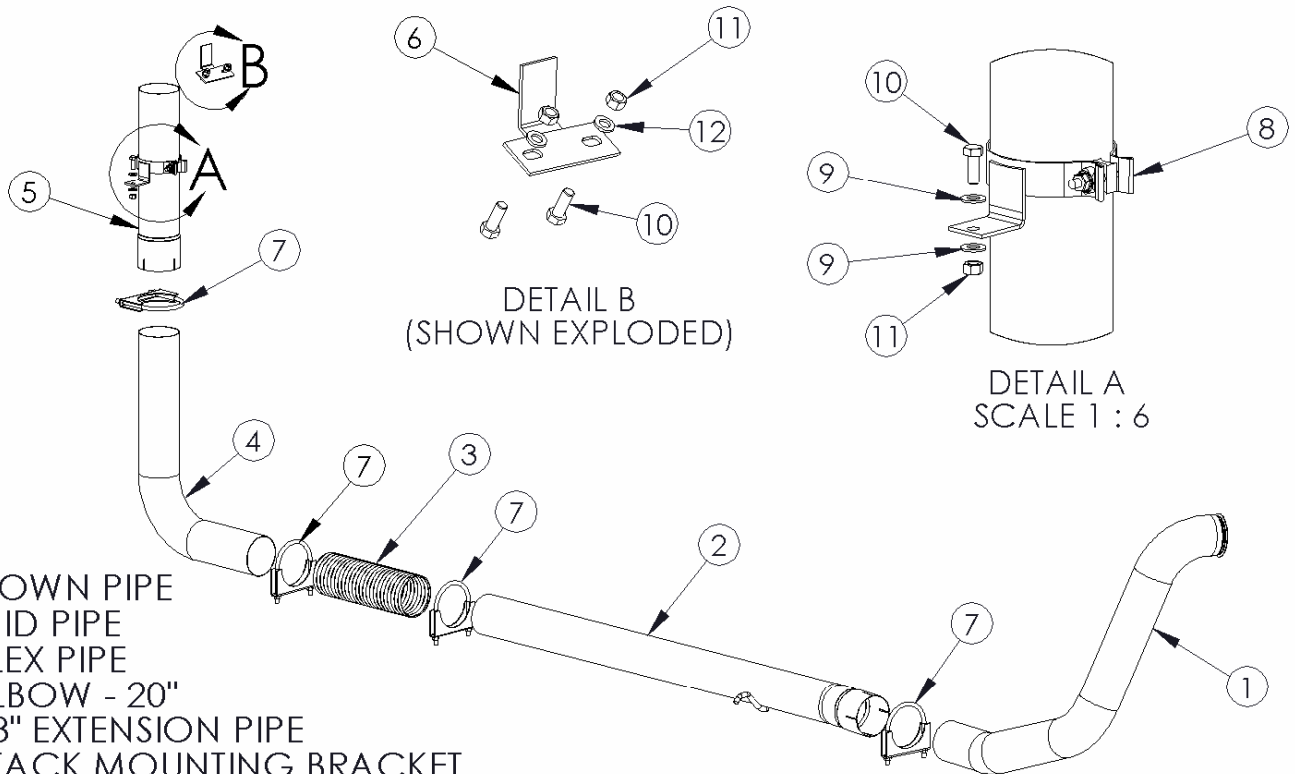

1. DOWN PIPE
2. MID PIPE
3. FLEX PIPE
4. ELBOW - 20"
5. 18" EXTENSION PIPE
6. STACK MOUNTING BRACKET
7. 4" CLAMP (4 PCS)
8. BED MOUNTING BRACKET
9. 3/8" WASHER (2 PCS)
10. 3/8" BOLT (3 PCS)
11. 3/8" NUT (3 PCS)
12. 3/8" LOCK WASHER (2 PCS)

NOTE: STACK SOLD SEPARATELY

### PLEASE READ BEFORE STARTING INSTALLATION

While MBRP Inc. has made every effort to ensure that all components of this system are of superior quality and properly packaged it is the installer's responsibility to ensure the following before removal of the factory exhaust:

- that ALL components shown above are present.
- that ALL mating components fit together.
- that there are no damaged components.
- that the system you have purchased is appropriate for your vehicle year, model and configuration.
- that the system will not interfere with any modifications previously installed or planned.
- that you have read and understand these instructions.

If you have any questions or are uncertain about any aspect of the installation of this system to your vehicle please contact your dealer before commencing installation.

## Removal of Stock System:

1. Apply a penetrating lubricant liberally to all exhaust fasteners, hangers and rubber insulators.
2. Loosen the nut on the band clamp located behind the catalytic converter using a 15mm wrench or socket.
3. If a hoist is being used for the installation, the original exhaust system can be removed in one piece by removing the passenger side shock. If a hoist is not being used the tail pipe must be cut behind the muffler to be removed.
4. Remove the muffler and tail pipe from the OEM rubber hangers and separate the stock exhaust at the slip joint located behind the catalytic converter and remove the muffler and tail pipe from the truck. **Re-install the passenger side shock.**
5. Remove the catalytic converter by removing the two nuts holding the inlet flange together using a 15mm wrench or socket.
6. Remove the down pipe from the turbo by removing the band clamp using an 11mm socket. **Retain the band clamp for the installation of the new down pipe.** Cut the down pipe in front of the transmission cross member to remove. (**Note:** The stock down pipe can be removed in one piece by removing the transmission cross member. It is recommended that this only be done by qualified, trained professionals using tools and equipment designed to safely carry out this procedure.)

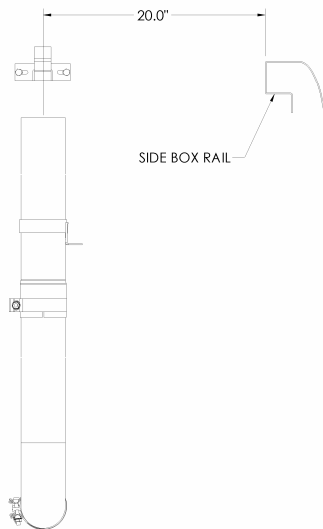

**Figure 1**

## Installation of MBRP Inc. "Smokers™"

1. Measure across 20" from the inside surface of the passenger side bed rail. Mark this location along the rail. This will be the approximate centerline of the **Stack** once installed. **Refer to Figure 1.**
2. Slide the **Band Clamp** (from **Stack** kit – purchased separately) over the **Stack**. Wedge the **Stack Mounting Bracket** between the **Band Clamp** and **Stack** and adjust to the bed rail height and tighten the **Band Clamp** slightly. Make sure the **Stack** is vertical and the **Stack Mounting Kit** is flush against the bed rail and centered on the measurement made in Step 1. Trace a circle around the base of the **Stack** and center punch the circles center. **Verify that the center punch hole is in line with your Mid Pipe and adjust accordingly.** This will be the center line of your **Stack**.
3. Align the **Stack** centered on the mark you made in Step 2. Mark the bolt hole location of the **Stack Mounting Bracket** onto the front rail of the bed. Center punch the marks and drill holes to accommodate the **3/8" Bolts** (included with the **Mounting Brackets**). **Refer to Figure 2.**



**Figure 2**



**Figure 3**

- Loosely attach the **Stack Mounting Bracket** to the front of the truck bed using a **3/8" Bolt** (included with the **Stack Mounting Bracket**). Set the **Stack** up in the bed and loosely attach it to the **Stack Mounting Bracket**. Make sure the **Stack** is vertical and in the desired position. **Refer to Figure 3.**



**Figure 4**

- Confirm that the base of the **Stack** is resting in the same position as in Step 2. Re-trace and center punch if needed. This is where the **18" Extension Pipe** will pass through the floor. Remove the **Stack** from the bed of the truck. Drill the hole using a 5" hole saw. It may be required to cut part of a bed floor rail away. **Refer to Figure 4.**



**Figure 5**

- Measure from the **18" Extension Pipe** slip joint to the **Mid Pipe**. Mark and cut the shorter side of the **Elbow** to the required length so that it lines up with the **Mid Pipe** in a place where the **Flex Pipe** can be placed between the **Mid Pipe** and the **Elbow**. It may be necessary to cut the **Elbow** again as cut the **Flex Pipe** to ensure proper fit. **Refer to Figure 5.**



**Figure 6**

- Attach the **Elbow** to the **18" Extension Pipe** slip joint and then attach the **Flex Pipe** to both the **Elbow** and the **Mid Pipe**. Be sure to slide the required **Clamps** over the **Elbow** and **Flex Pipe** before connecting to the **Mid Pipe**. **Refer to Figure 6.**



8. Slide the **Bed Mounting Bracket** onto the **18" Extension Pipe**. Install the assembly on the outlet of the **Elbow** along with the required **Clamp**. Reinstall the **Stack** by sliding the inlet over the **18" Extension Pipe** and then securing the **Stack** to the **Stack Mounting Bracket** with the **Clamp** supplied with your **Stack**. Align the system and tighten all **Clamps** to ensure that your "Smokers™" exhaust system remains properly aligned.
9. Slide the **Bed Mounting Bracket** to the desired position on the **18" Extension Pipe** to allow installation of the mounting hardware. Ensure that the **Stack** is vertical. Trace the **Bed Mounting Bracket** hole from the bracket to the floor and drill a hole to accommodate the **3/8"** hardware supplied. Secure the **Bed Mounting Bracket** to the truck and tighten the **Clamp** to the **18" Extension Pipe**. This Clamp will ensure the Stack remains in position and doesn't vibrate.
10. Check along the whole length of the exhaust system to ensure that there is adequate clearance around fuel lines, brake lines and any wiring. If any interference is detected relocate or adjust.



Shown with 6" x 36" Stack (B1610)

**Congratulations!** You are ready to begin experiencing the improved power, sound and driving excitement of your MBRP Inc. "Smokers™". We are certain that you will enjoy your purchase.