

S8210

**99-03 FORD SUPER DUTY 7.3L TURBO BACK
5" SMOKERS™**

MBRP
INC.

PERFORMANCE EXHAUST

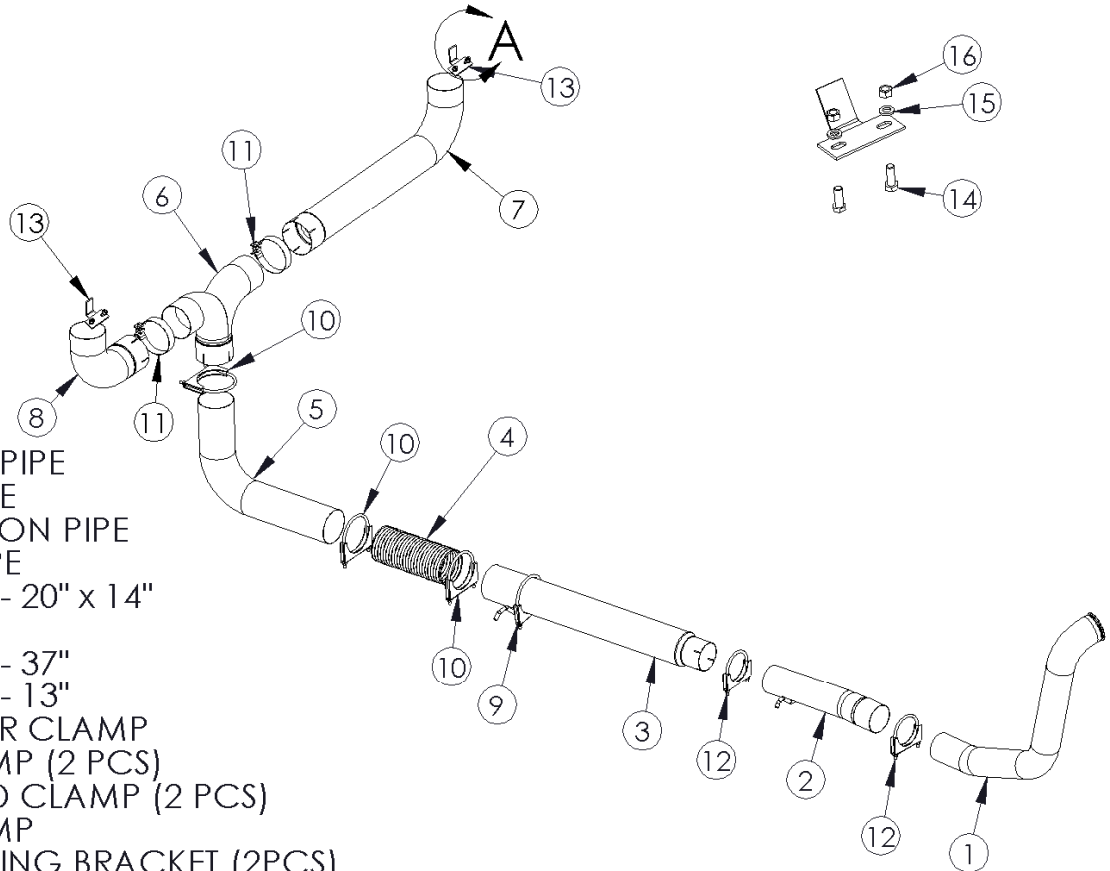

1. DOWN PIPE
2. MID PIPE
3. EXTENSION PIPE
4. FLEX PIPE
5. ELBOW - 20" x 14"
6. T-PIPE
7. ELBOW - 37"
8. ELBOW - 13"
9. HANGER CLAMP
10. 5" CLAMP (2 PCS)
11. 5" BAND CLAMP (2 PCS)
12. 4" CLAMP
13. MOUNTING BRACKET (2PCS)
14. HEX BOLT 3/8" (4PCS)
15. LOCK WASHER 3/8" (4PCS)
16. HEX NUT 3/8" (4PCS)

NOTE: STACKS SOLD SEPARATELY

PLEASE READ BEFORE STARTING INSTALLATION

While MBRP Inc. has made every effort to ensure that all components of this system are of superior quality and properly packaged it is the installer's responsibility to ensure the following before removal of the factory exhaust:

- that ALL components shown above are present.
- that ALL mating components fit together.
- that there are no damaged components.
- that the system you have purchased is appropriate for your vehicle year, model and configuration.
- that the system will not interfere with any modifications previously installed or planned.
- that you have read and understand these instructions.

If you have any questions or are uncertain about any aspect of the installation of this system to your vehicle please contact your dealer before commencing installation.

Removal of Stock system:

1. Apply a penetrating lubricant liberally to all exhaust fasteners, hangers and rubber insulators.
2. Loosen the nut on the band clamp located behind the catalytic converter using a 15mm wrench or socket.
3. If a hoist is being used for the installation, the original exhaust system can be removed in one piece by removing the passenger side shock. If a hoist is not being used the tail pipe must be cut behind the muffler to be removed.
4. Remove the muffler and tail pipe from the OEM rubber hangers and separate the stock exhaust at the slip joint located behind the catalytic converter and remove the muffler and tail pipe from under the truck. **Re-install the passenger side shock.**
5. Remove the catalytic converter by removing the two nuts holding the inlet flange together using a 15mm wrench or socket.
6. Remove the down pipe from the turbo by removing the band clamp using an 11mm socket. **Retain the band clamp for the installation of the new down pipe.** Cut the down pipe in front of the transmission cross member to remove. (**Note:** The stock down pipe can be removed in one piece by removing the transmission cross member. It is recommended that this only be done by qualified, trained professionals using tools and equipment designed to safely carry out this procedure.)

Installing Your MBRPinc. "Smokers™":



Figure 1

1. Install the **Down Pipe** in the same position as the stock down pipe and attach the flared end to the turbo using the stock band clamp. Do not fully tighten until all components are in place. **Refer to Figure 1.**

2. Attach the **Mid Pipe** to the **Down Pipe** using a 4" **Clamp** to secure the slip joint. **Refer to Figure 2.**

3. Loosely attach the **Extension Pipe** to the **Mid Pipe**. The **Extension Pipe** may need to be trimmed to mate up to the **Flex Pipe** in the rear section of the "Smokers™".



Figure 2



Figure 3



Figure 4



Figure 5



Figure 6



Figure 7

4. Loosely assemble the in bed portion of the **T-Pipe Assembly**. Some models may require trimming of the **T-Pipe** in order to accommodate the width of the truck bed and the **Stacks**. Be sure to place the **5" Band Clamps** over the pieces before they are assembled. **Refer to Figure 3.**

5. Place the **Stacks** onto the **T-Pipe Assembly** and place into the desired position in the truck bed. The **37" Elbow** should be on the driver side so that the **T-Pipe** passes through the bed floor on the passenger side. **Refer to Figure 3.**

6. Place the **Mounting Brackets** between the **Stacks** and the front of the truck bed so that the **Stacks** are properly spaced from the front of the truck bed. Center a **Mounting Bracket** onto each **Stack** and mark the front of the truck bed in the center of the slotted holes in the **Mounting Brackets**. Center punch the marks and drill holes to accommodate a **3/8" Bolt**. **Refer to Figure 4.**

7. Loosely attach the **Mounting Brackets** to the front of the truck bed using the **3/8"** hardware supplied. Set the **Stacks** up in the bed and loosely attach them to the **Mounting Brackets**. Make sure the **Stacks** are in the desired position and the **T-Pipe Assembly** is level.

8. Mark the bed floor where the **T-Pipe** is resting. MBRP Inc. recommends tracing around where the **T-Pipe** meets the bed floor. **Refer to Figure 5.** Remove **Stacks** and **T-Pipe Assembly** from the bed of the truck. Find the center of the circle traced onto the bed floor, mark and center punch it. Go under the vehicle and locate the center punch mark. This marks the location where you are going to cut a hole for the **T-Pipe** to pass through the bed of the truck. If you cannot find the center punch mark use a small drill to create a pilot hole. Make sure that there is clearance for the **20"x 14" Elbow** to pass by any frame cross members. Remove or modify any heat shields that may cause interference.

9. Cut a hole through the truck bed providing adequate clearance around the part of the **T-Pipe** that passes through the truck bed. MBRP Inc. recommends using a **6"** diameter hole saw. It may be necessary to cut part of a bed rail away. **Refer to Figure 6.**

10. Set the **T-Pipe Assembly** at the desired height from the floor of the bed (This will set the height of the **Stacks**). Using spacers to hold the **T-Pipe** at the desired height, loosely attach the **Stacks** to the **Mounting Brackets** making sure that they are straight. This will hold the assembly steady while you line the system up to the exhaust under the vehicle. **Refer to Figure 7.**



Figure 8

12. Measure from the **T-Pipe** slip joint to the exhaust system that you are connecting to. Mark and cut the shorter side of the **20"x 14" Elbow** to the required length so that it lines up with the **Extension Pipe** of the exhaust system. **Refer to Figure 8.**

13. Loosely install the **20"x 14" Elbow** into the **T-Pipe**. Measure and mark the **20"x 14" Elbow** and **Extension Pipe** so that you will use the full length (12") of **Flex Pipe**. Cut the pieces to the required length. Make sure you allow overlap for clamping. **Refer to Figure 9.**



Figure 9

14. Attach the **20"x 14" Elbow** to the **T-Pipe** slip joint and then attach the **Flex Pipe** to both the **20"x 14" Elbow** and the front part of the exhaust system and the **Extension Pipe**. Be sure to slide the required **Clamps** over the **20"x 14" Elbow** and **Flex Pipe** before connecting it to the **Extension Pipe**.

15. Make sure that the **Mounting Brackets** are centered on the **Stacks** and tighten the fasteners holding the **Mounting Brackets** to the front of the truck bed. Tighten all **Clamps** making sure that the **Stacks** remains properly aligned.

16. Install remaining **Clamps** around pipes where required. Check along the whole length of the exhaust system to ensure that there is adequate clearance around the fuel and brake lines or any wiring. If any interference is detected relocate or adjust.



Shown with 6" Stacks

Congratulations! You are ready to begin enjoying the improved performance and driving experience of your MBRP Inc. *"Smokers™"*. We know you will enjoy your purchase.