

S5034

07-10 CADILLAC ESCALADE EXT, ESV/GMC
YUKON DENALI XL, 6.2L CAT BACK SINGLE

MBRP INC.
PERFORMANCE EXHAUST

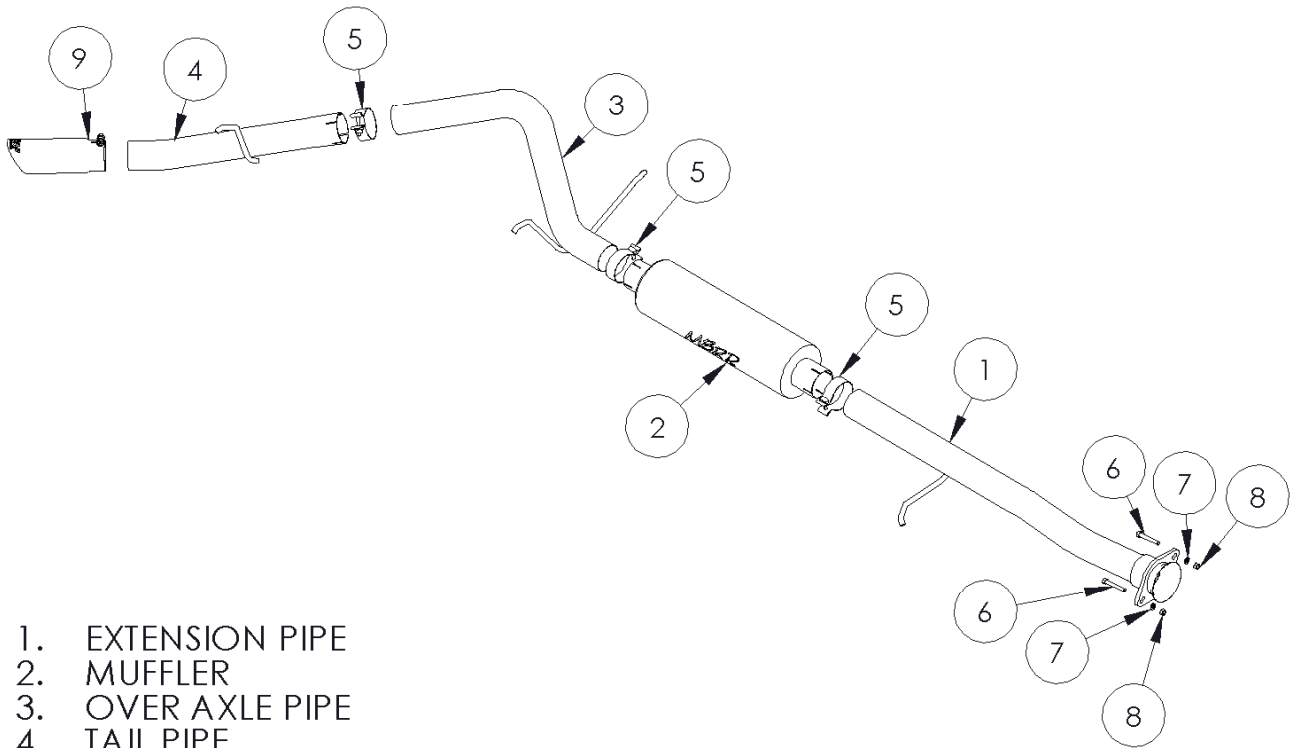

1. EXTENSION PIPE
2. MUFFLER
3. OVER AXLE PIPE
4. TAIL PIPE
5. 3" CLAMPS (3PCS)
6. HEX BOLT 3/8" X 2 1/2" (2PCS)
7. LOCK WASHER 3/8" (2PCS)
8. HEX NUT 3/8" (2PCS)
9. EXHAUST TIP

SADDLE CLAMPS USED IN ALUMINIZED SYSTEMS

PLEASE READ BEFORE STARTING INSTALLATION

While MBRP Inc. has made every effort to ensure that all components of this system are of superior quality and properly packaged, it is the installer's responsibility to ensure the following before removal of the factory exhaust:

- that ALL components shown above are present.
- that ALL mating components fit together.
- that there are no damaged components.
- that the system you have purchased is appropriate for your vehicle year, model and configuration.
- that the system will not interfere with any modifications previously installed or planned.
- that you have read and understand these instructions.

If you have any questions or are uncertain about any aspect of the installation of this system to your vehicle please contact your dealer before commencing installation.



Figure 1

Removal of Stock System:

1. Apply a penetrating lubricant liberally to all exhaust fasteners, hangers and rubber insulators.



Figure 2

2. Remove the hangers from the rubber insulators and remove the exhaust from the vehicle. The tail pipe will need to be cut to clear the rear axle. **Refer to Figures 1&2.**

3. Remove the hardware holding the front flange together and disconnect exhaust system. **Refer to Figure 3.**

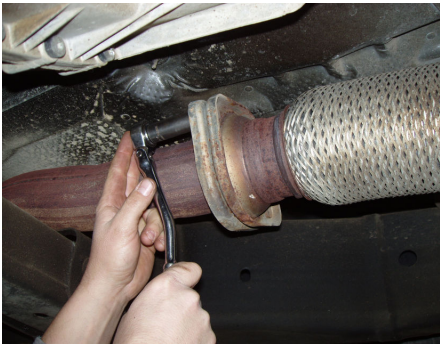

Figure 3

4. Remove the exhaust from underneath the vehicle. **Refer to Figure 4.**



Figure 4

Installation of MBRP Inc. Performance Exhaust:

1. Loosely attach the **Extension Pipe** to the flange using the fasteners provided. Slide the **Extension Pipe** hanger into the factory rubber insulator located on the frame. **Refer to Figures 5 & 6.**



Figure 5



Figure 6

2. Slide a **3" Clamp** over the rear of **Extension Pipe** and install the **Muffler** onto the **Extension Pipe**. Refer to **Figure 7**.



Figure 7

3. Slide a **3" Clamp** over the outlet side of the **Muffler**. Feed the **Over Axle Pipe** into the outlet of the **Muffler**. Install the **Over Axle Pipe** hangers into the factory rubber insulators located directly above the hangers. Refer to **Figure 8**.

4. Slide a **3" Clamp** onto the **Over Axle Pipe** and install onto the **Tail Pipe**. Slide the **Tail Pipe** hanger into rubber insulator located on the frame. Refer to **Figure 9**.



Figure 8

5. Install and adjust the **Exhaust Tip** to suit. Use a 17mm wrench to tighten the lock bolt located on the **Exhaust Tip**.

6. Align the exhaust as required and starting at the front of the system, tighten all clamps and connections.

7. Check along the whole length of the exhaust system to ensure that there is adequate clearance around the spare tire, fuel and brake lines or any wiring. If any interference is detected relocate or adjust.



Figure 9



Congratulations! You are ready to begin experiencing the improved power, sound and driving excitement of your MBRP Inc. performance exhaust system. We know you will enjoy your purchase.