

# AT-9301SP

SLIP-ON EXHAUST ASSEMBLY, SPORT  
2020 KAWASAKI TERYX KRX 1000

# MBRP

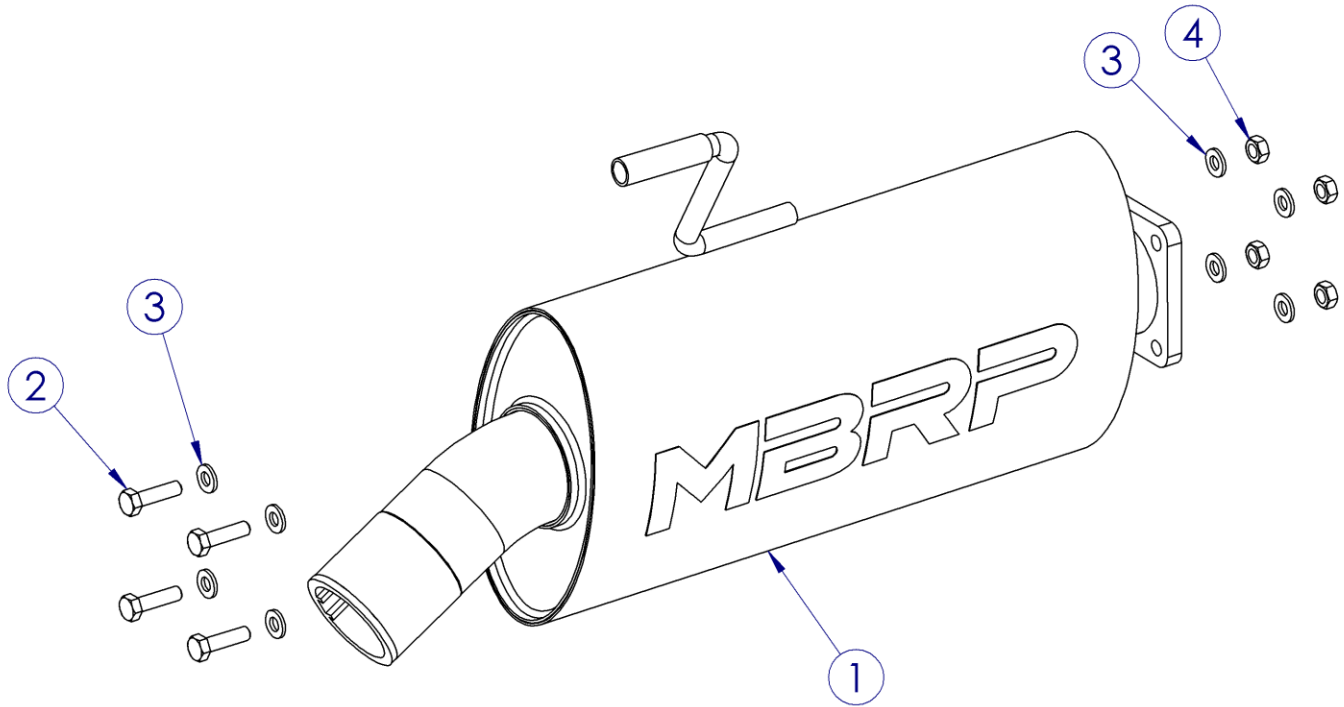

ITEM NO.	DESCRIPTION	QTY.
1	MUFFLER ASSEMBLY	1
2	HEX BOLT	4
3	LOCK WASHER	8
4	HEX NUT	4

## PLEASE READ BEFORE STARTING INSTALLATION

**While MBRP Ltd. has made every effort to ensure that all components of this system are of superior quality and properly packaged, it is the installer's responsibility to ensure the following before removal of the factory exhaust:**

- that ALL components shown above are present.
- that ALL mating components fit together.
- that there are no damaged components.
- that the system you have purchased is appropriate for your vehicle year, model and configuration.
- that the system will not interfere with any modifications previously installed or planned.
- that you have read and understand these instructions.

If you have any questions or are uncertain about any aspect of the installation of this system to your vehicle please contact your dealer before commencing installation.

# MBRP

## Removal of Stock Exhaust:

1. Remove the four (4) nuts from the outlet flange of the stock front pipe. **Refer to Figure 1**
2. Remove the two (2) bolts securing the lower isolator mount to the vehicle frame. **Refer to Figure 2**
3. Remove the single bolt holding the front inner isolator mount to the vehicle. **Refer to Figure 3**
4. Finally, while supporting the stock muffler, remove the two (2) bolts securing the upper rear isolator mount (**Refer to Figure 4**), then remove the muffler. Retain the isolator mount and bolts as they will be reused.



Figure 1



Figure 2



Figure 3



Figure 4

## Installation of MBRP Exhaust:

1. Reinstall the upper rear isolator mount, but leave the bolts loose enough that the bracket can move slightly. **Refer to Figure 4.**
2. Make sure that the stock circular gasket is in place at the outlet of the front pipe. If it came off with the muffler, put it back in place.
3. Install the **Muffler Assembly** by sliding the hanger into the isolator mount and positioning the inlet flange onto the stock front pipe flange. Place one of the **Hex Bolts** with a **Lock Washer** through one of the flange holes and loosely secure it with a **Lock Washer** and **Hex Bolt** to hold the **Muffler Assembly** in place. **Refer to Figure 5**
4. Loosely install the remaining **Hex Bolts, Lock Washers, and Hex Nuts** at the flange connection. Once all bolts are in place, the flange hardware can be fully tightened. **Refer to Figure 5**  
*It is recommended that the hardware be retightened after the first hour of operation.*
5. Finally, fully tighten the bolts securing the isolator mount.

*Note: In order to maintain optimal performance, the spark arrestor screen should be cleaned after every 30-35 hours of use.*



Figure 5

**Congratulations!** You are ready to begin experiencing the improved performance and driving excitement of your MBRP Exhaust upgrade. We know you will enjoy your purchase.