

S5246

2011-2016 FORD F250/350, 6.2L,
SUPERCAB / CREW CAB,
RESONATOR BACK, 4.0" SINGLE

MBRP®

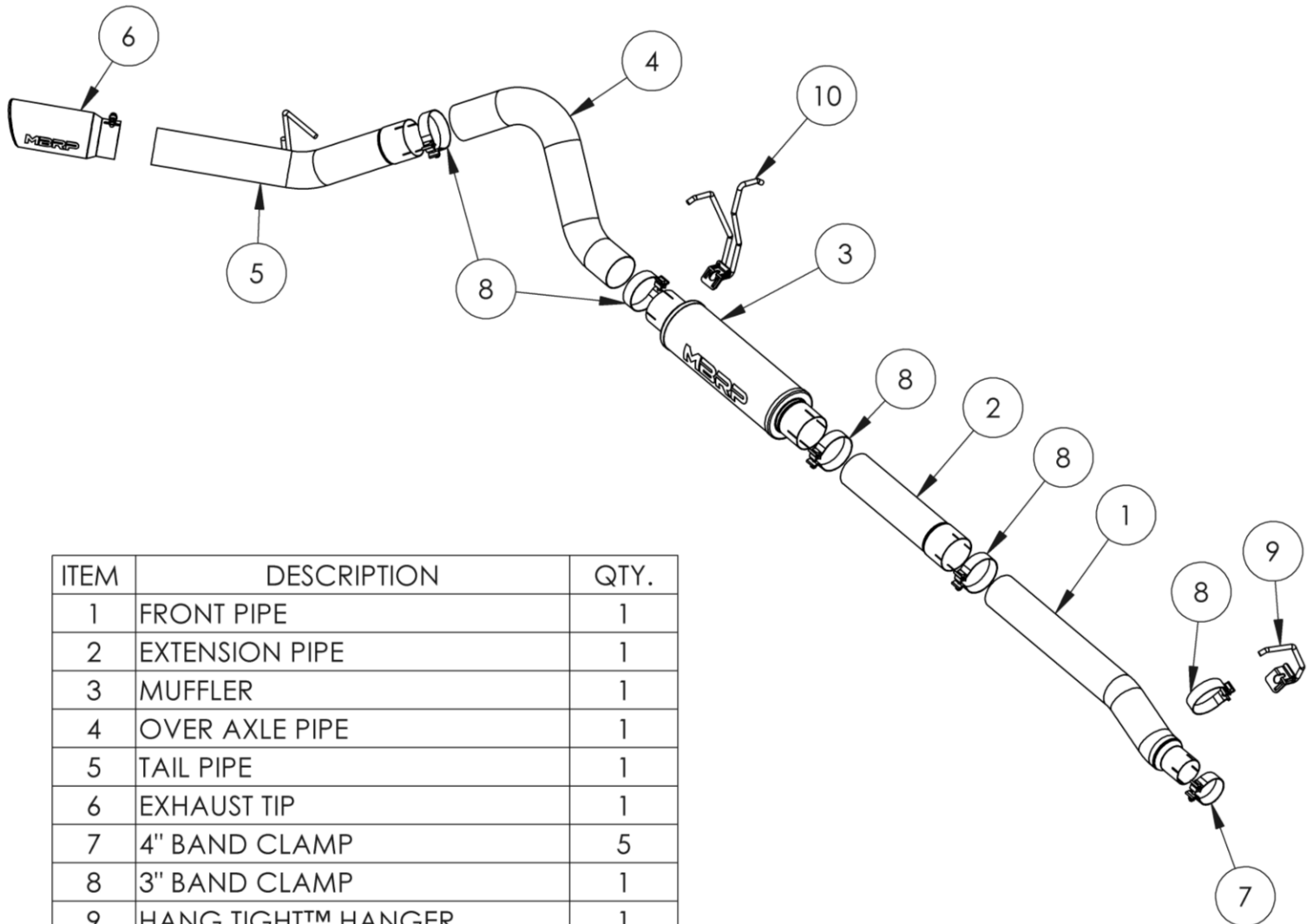

ITEM	DESCRIPTION	QTY.
1	FRONT PIPE	1
2	EXTENSION PIPE	1
3	MUFFLER	1
4	OVER AXLE PIPE	1
5	TAIL PIPE	1
6	EXHAUST TIP	1
7	4" BAND CLAMP	5
8	3" BAND CLAMP	1
9	HANG TIGHT™ HANGER	1
10	DUAL HANG TIGHT™ HANGER	1

PLEASE READ BEFORE STARTING INSTALLATION

While MBRP has made every effort to ensure that all components of this system are of superior quality and properly packaged, it is the installer's responsibility to ensure the following before removal of the factory exhaust:

- that ALL components shown above are present.
- that ALL mating components fit together.
- that there are no damaged components.
- that the system you have purchased is appropriate for your vehicle year, model and configuration.
- that the system will not interfere with any modifications previously installed or planned.
- that you have read and understand these instructions.

If you have any questions or are uncertain about any aspect of the installation of this system to your vehicle please contact your dealer before commencing installation.

MBRP

Removal of Stock System:



Figure 1

1. Apply a penetrating lubricant liberally to all exhaust fasteners, hangers, and rubber insulators.
2. Loosen the clamp located rearward of the pipe **shown in Figure 1**.
3. Remove the hangers from the rubber insulators and remove the exhaust from the vehicle. **Refer to Figure 2.**



Figure 2

Installation of MBRP Performance Exhaust:

1. Install the **Hang Tight™ Hangers** onto **4.0" Clamps** using the procedure shown below. (Hang Tight™ Hanger not exactly as shown).

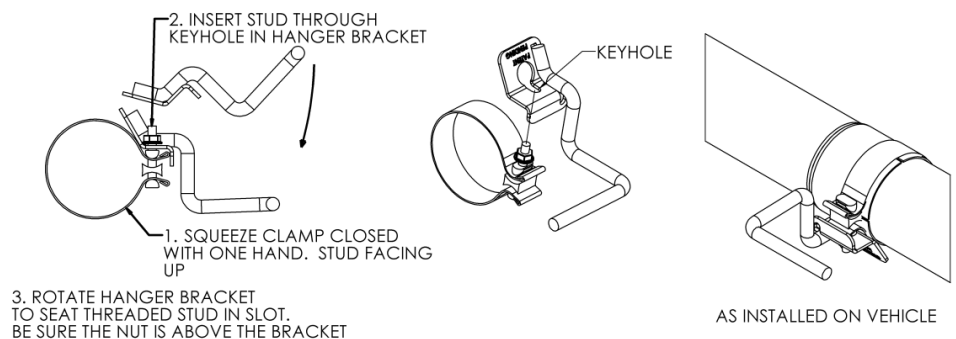

Figure 3

2. Install the front **Hang Tight™ Hanger Assembly** (single) onto the 4.0" section of the **Front Pipe** between the bends.

Refer to title sheet for approximate location.

Note: Front Pipe may need trimming, refer to illustration below.



Figure 4

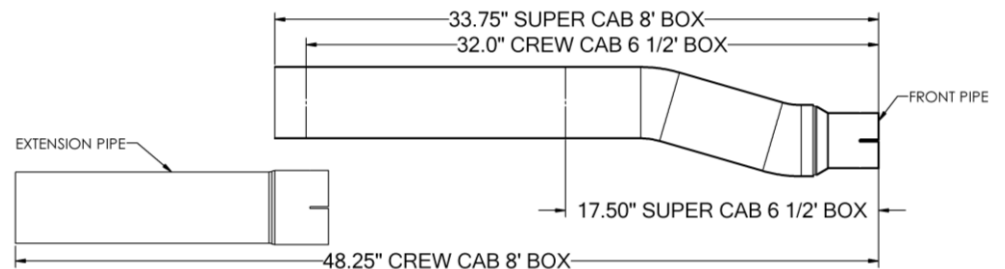

3. Install the **Front Pipe** to the vehicle using the **3" Clamp** provided. Place the **Hang Tight™ Hanger** into the existing rubber isolator. Install the **Extension Pipe** to the **Front Pipe** if required. **Refer to Figure 3.**

MBRP



Figure 5

4. Install the **Muffler** onto the **Front Pipe/Extension Pipe** using a **4” Clamp**. Install the rear **Hang Tight™ Hanger Assembly (Dual)** onto the outlet of the **Muffler**. Place the hangers into the existing rubber isolators. **Refer to Figures 4 & 5.**

5. Loosely install the **Over Axle Pipe** connecting it to the **Muffler** outlet and securing it with the previously installed **Hang Tight™ Hanger Assembly**. **Refer to Figure 6.**



Figure 6

6. Loosely install the **Tail Pipe** connecting it to the **Over Axle** and securing it with a **4” Clamp**.

7. Install and adjust the **Exhaust Tip** to suit. **Refer to Figure 7.**



Figure 7

8. Align the exhaust as required. Tighten all hardware and clamps, starting at the front and working rearward to secure the system. Check along the full length of the exhaust system to ensure there is adequate clearance for fuel lines, vent lines, brake lines, frame, bodywork, suspension, and any wiring, etc. If there is any interference detected, relocate, or adjust to provide adequate clearance. Ensure all clamp connections are secure and components are unable to rotate or slide. Band clamps require approximately 45 lb-ft (60 N-m) of torque. Verify clearances, system security and band clamp torque after 30-60 miles (50-100 km) of driving.

Congratulations! You are ready to begin experiencing the improved power, sound and driving excitement of your **MBRP** performance exhaust system. We know you will enjoy your purchase.



Figure 8