

**S6114**

**03-04 DODGE 5.9L, I-6 TURBO, 2500/3500,  
5" TURBO BACK**

**MBRP**  
INC.

**PERFORMANCE EXHAUST**

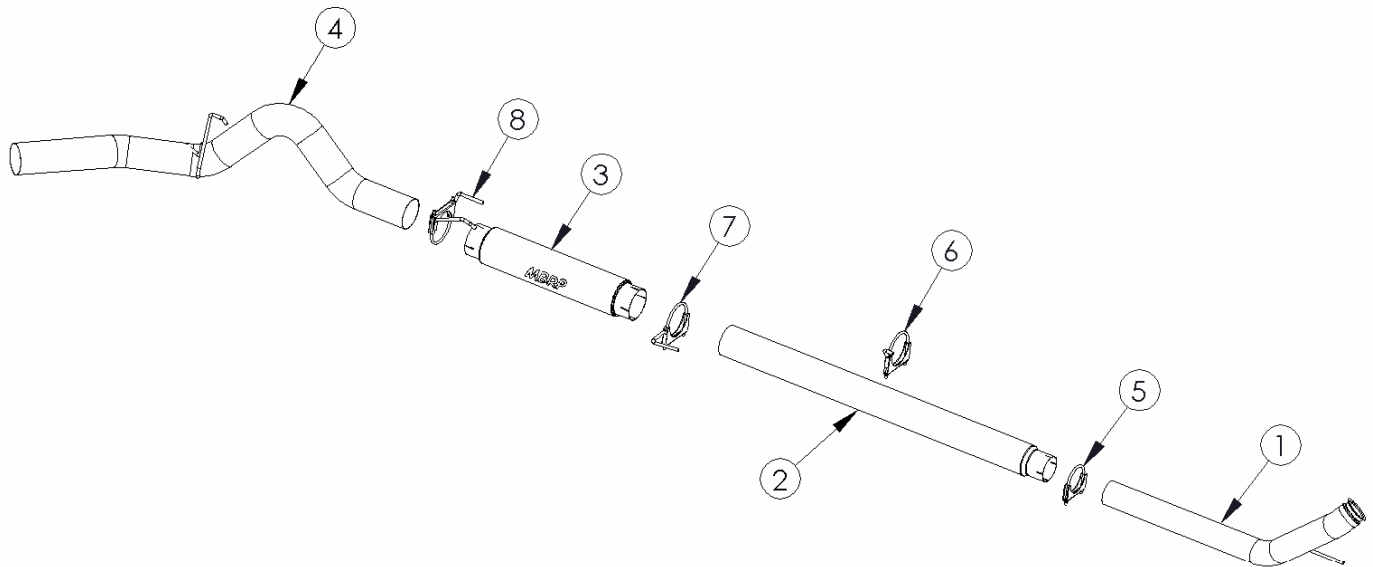

1. DOWN PIPE
2. 4" TO 5" EXTENSION PIPE - 59"
3. HIGH FLOW MUFFLER ASSEMBLY
4. TAIL PIPE
5. 4" CLAMP
6. 5" HANGER CLAMP
7. 5" HANGER CLAMP
8. 5" HANGER CLAMP

### **PLEASE READ BEFORE STARTING INSTALATION**

**While MBRP Inc. has made every effort to ensure that all components of this system are of superior quality and properly packaged it is the installer's responsibility to ensure the following before removal of the factory exhaust:**

- that ALL components shown above are present.
- that ALL mating components fit together.
- that there are no damaged components.
- that the system you have purchased is appropriate for your vehicle year, model and configuration.
- that the system will not interfere with any modifications previously installed or planned.
- that you have read and understand these instructions.

If you have any questions or are uncertain about any aspect of the installation of this system to your vehicle please contact your dealer before commencing installation.

### Removal of stock system:

1. Apply a penetrating lubricant liberally to all exhaust fasteners, hangers and rubber insulators.
2. Remove the exhaust system from the rubber insulators and remove all of the clamps from the system.
3. Separate the slip joint behind the muffler and remove the tail pipe. Next, separate the slip joint connecting the down pipe and the extension pipe to remove the muffler and extension pipe. Now loosen the band clamp connecting the down pipe to the turbo and remove the down pipe. **Do not discard the band clamp as it is required for the installation.**
4. Remove the spare tire. You may not be able to reinstall your spare tire after the installation of this exhaust system.

### Installation of MBRP Inc. Performance Exhaust:

1. Install the **Down Pipe** in the same position as the stock down pipe by sliding the hanger into the OEM hanger bracket and then attaching the flared end to the turbo using the stock band clamp. Do not fully tighten until all components are in place.
2. Install the **4" to 5" Extension Pipe** over the **Down Pipe**. The **4" to 5" Extension Pipe** provides the required length to fit a **Quad Cab Long Bed** truck. The **4" to 5" Extension Pipe** will have to be cut to fit all other vehicles. **Installation Tip:** Temporarily install the **Muffler** and **Tail Pipe** using the factory rubber insulators and the **Hanger Clamp**. Measure from the **Muffler** to the **Extension Pipe** or **Mid Pipe** to determine the length required. Cut the pipe to the required length.

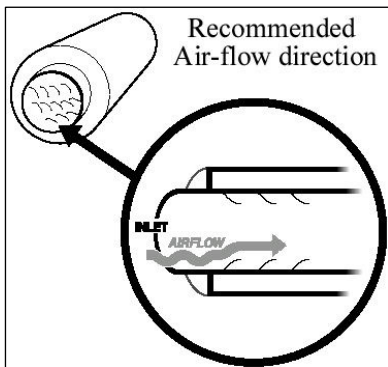

3. Install the **Muffler** over the required pipe so that the exhaust will flow smoothly over the louvers. Refer to the illustration on the left.
4. Install the **Hanger Clamp** into the two OEM rubber hangers located on the frame near the inlet of the **Muffler**.
5. Remove the factory rubber insulator for the factory tail pipe and install it onto the **Tail Pipe** hanger. Install the **Tail Pipe** from the rear of the truck, over the axle and attach to the outlet of the **Muffler**. Finish hanging the **Tail Pipe**.
6. Install the **Hanger Clamp** into the two OEM rubber hangers located above the outlet of the **Muffler**.
7. Install the provided clamps around pipes where needed. Adjust the **Tail Pipe** and check along the whole length of exhaust system to ensure there is adequate clearance around the fuel and brake lines or any wiring. If any interference is relocate or adjust.
8. Make sure exhaust is in place before tightening clamps. Start at the front of the exhaust system and begin tightening all connections.
9. If a tip has been purchased, install and adjust to suit. Using a 17mm wrench tighten lock bolt located on **Tip**. **The Tip is not included with this kit.** Tips may be purchased separately, check with your dealer.

**Congratulations!** You are ready to begin enjoying the improved performance and driving experience of your MBRP Inc. performance exhaust system. We hope you enjoy your purchase.