

S6248TD

2011 FORD SUPER-DUTY F250/350/450 6.7L
4" FILTER-BACK TURN DOWN EXHAUST

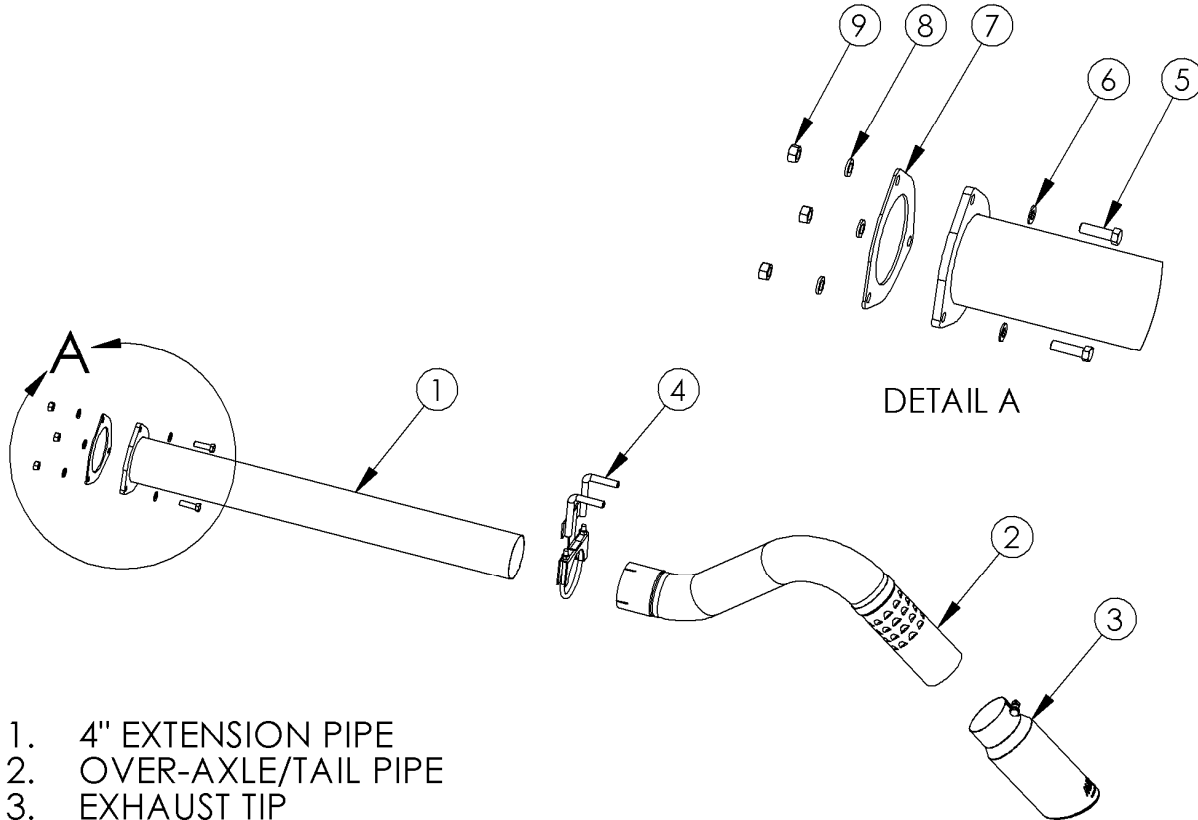

1. 4" EXTENSION PIPE
2. OVER-AXLE/TAIL PIPE
3. EXHAUST TIP
4. 4" HANGER CLAMP
5. 7/16" HEX BOLT (3 PCS)
6. WASHER (3 PCS)
7. GASKET
8. LOCK WASHER (3 PCS)
9. HEX NUT (3 PCS)

PLEASE READ BEFORE STARTING INSTALLATION

While MBRP Inc. has made every effort to ensure that all components of this system are of superior quality and properly packaged it is the installer's responsibility to ensure the following before removal of the factory exhaust:

- that ALL components shown above are present.
- that ALL mating components fit together.
- that there are no damaged components.
- that the system you have purchased is appropriate for your vehicle year, model and configuration.
- that the system will not interfere with any modifications previously installed or planned.
- that you have read and understand these instructions.

If you have any questions or are uncertain about any aspect of the installation of this system to your vehicle please contact your dealer before commencing installation.

Removal of Stock System

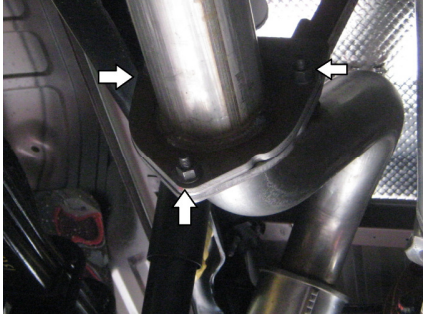

Figure 1

1. Apply some penetrating lubricant to all exhaust fasteners, hangers, and rubber insulators.
2. Loosen the three (3) nuts securing the extension pipe flange to the over-axle pipe. **Refer to Figure 1.**
3. Remove the factory over-axle/tail pipe.
4. Loosen the three (3) nuts securing the extension pipe to the flange directly behind the exhaust filter and remove the extension pipe. **Refer to Figure 2.**

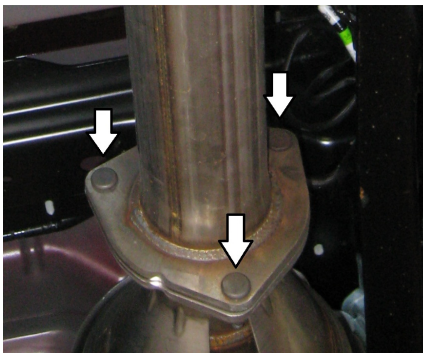

Figure 2

Installation of MBRP Inc. Performance Exhaust

1. The **Extension Pipe** is pre-cut for the 172.4" (crew-cab long-box) wheelbase. Cut the **Extension Pipe** to the appropriate length for the installation vehicle. **Refer to Figure 3.**

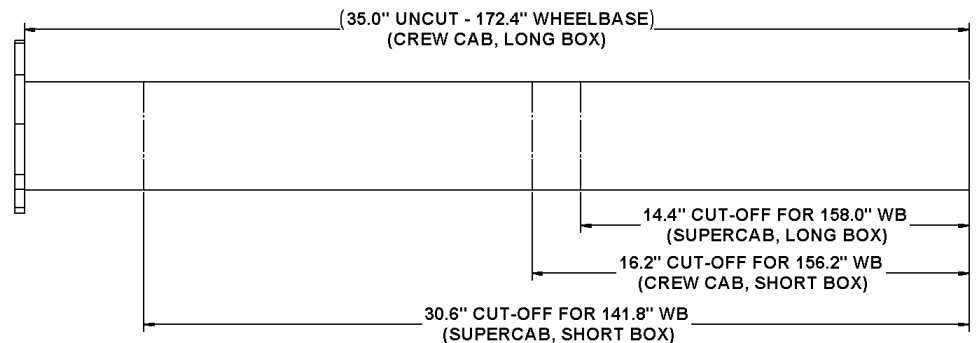

Figure 3

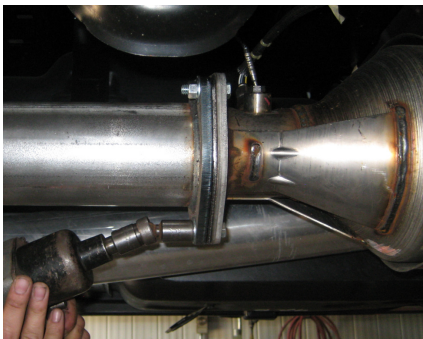

Figure 4

2. Mate the **Extension Pipe** flange to the stock exhaust flange with the **Gasket** between them and fasten the flanges together with the hardware provided. **Refer to Figure 4.**
3. Fit the **Hanger Clamp** loosely over the end of the extension pipe and insert the hangers into the rubber isolators.
4. Install the **Over-Axle/Tail Pipe** onto the **Extension Pipe** and secure it by tightening the **Hanger Clamp**.
5. Install the **Exhaust Tip** using a 17mm wrench. Position the **Exhaust Tip** in the desired location, cutting the **Tail Pipe** if required. **Refer to Figure 5.**
6. Align the exhaust as required and fully tighten the **Hanger Clamp**.
7. Ensure that there is adequate clearance around any vehicle components.



Figure 5

Congratulations! You are ready to begin experiencing the improved power, sound, and driving experience of your MBRP Inc. performance exhaust system. We know you will enjoy your purchase.