

S7258

2011-2014 FORD MUSTANG GT,
2011-2012 FORD MUSTANG SHELBY GT500,
STREET SERIES, CAT BACK, 3", DUAL SPLIT
REAR

MBRP®

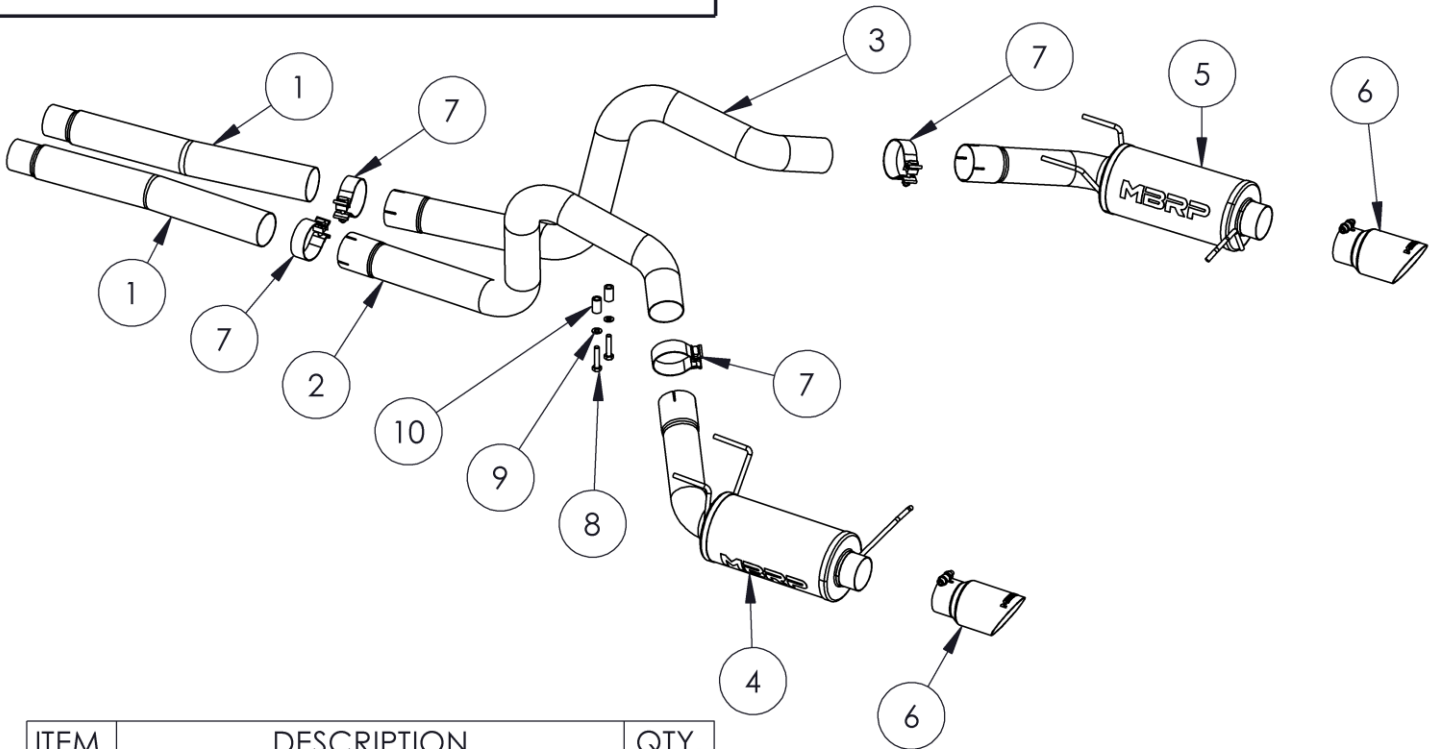

ITEM	DESCRIPTION	QTY.
1	MID PIPE	2
2	DRIVER SIDE OVER-AXLE PIPE	1
3	PASSENGER SIDE OVER-AXLE PIPE	1
4	DRIVER SIDE MUFFLER	1
5	PASSENGER SIDE MUFFLER	1
6	EXHAUST TIP	2
7	3.0" CLAMP	4
8	M10x50 BOLT	2
9	M10 WASHER	2
10	SPACER	2

PLEASE READ BEFORE STARTING INSTALLATION

While MBRP has made every effort to ensure that all components of this system are of superior quality and properly packaged, it is the installer's responsibility to ensure the following before removal of the factory exhaust:

- that ALL components shown above are present.
- that ALL mating components fit together.
- that there are no damaged components.
- that the system you have purchased is appropriate for your vehicle year, model and configuration.
- that the system will not interfere with any modifications previously installed or planned.
- that you have read and understand these instructions.

If you have any questions or are uncertain about any aspect of the installation of this system to your vehicle please contact your dealer before commencing installation.

MBRP



Figure 1



Figure 2



Figure 3



Figure 4



Figure 5

Removal of Stock System:

1. Apply a penetrating lubricant liberally to all exhaust fasteners, hangers and rubber insulators.

2. Loosen both OEM clamps located at each muffler inlet, and both OEM band clamps at the H Pipe outlet. Lift the lock tab to slide the band clamp rearward. Do not discard these clamps.
Refer to Figures 1 and 2.

3. Remove the OEM over axle pipes by lowering the inlet ends and pulling them out towards the front of the car.

4. Remove both M10 bolts that secure the Panhard Bar Brace to the Driver Side Frame rail. Pull the brace downward to allow more room to remove the OEM mufflers. Slide the rubber isolator off the rearmost muffler hangers, then slide the muffler assemblies forward to remove them from the car.
Refer to Figure 3.

Installation of MBRP Performance Exhaust:

1. Install the **Driver Side** and **Passenger Side Mufflers** by inserting the 2 forward hangers into the OEM isolators and sliding the muffler forward followed by inserting the rear hanger into the rear OEM isolators.

Refer to Figures 4 and 5.

MBRP



Figure 6

2. Install both **Driver Side** and **Passenger Side Over-Axle Pipes** over the axle and into the **Driver** and **Passenger Mufflers**. Be sure that the supplied **3.0" Clamps** are installed over the joint. Do not tighten yet.

Refer to Figure 6.



Figure 7

3. Install the **Mid Pipes** onto the **Driver Side** and **Passenger Side Over-Axle Pipes** using the remaining **3.0" Clamps**. Align the **Mid Pipes** so the inlets are parallel while leaving the clamps loose.

4. Install the OEM band clamp removed in Step 2 onto the inlet ends of the **Mid Pipes**. Slide the **Mid Pipes** onto the outlet end of the H Pipe. Do not tighten yet. **Refer to Figure 7.**

5. Tighten all clamps just enough to hold the pipes in place but allowing for adjustment.



Figure 8

6. Reattach the Panhard Bar Brace to the Driver side Frame rail with the supplied **M10x50 bolts** and **Spacers** to allow more clearance for the **Driver Side Over-Axle Pipe**. Install the **Exhaust Tips** onto the Muffler outlets. **Refer to Figures 8 and 9.**

7. Align the **Exhaust Tips** in the rear fascia and tighten all hardware and clamps, starting at the front and working rearward to secure the system. Check along the full length of the exhaust system to ensure there is adequate clearance for fuel lines, vent lines, brake lines, frame, bodywork, suspension, and any wiring, etc. If there is any interference detected, relocate, or adjust to provide adequate clearance. Ensure all clamp connections are secure and components are unable to rotate or slide. Band clamps require approximately 45 lb-ft (60 N-m) of torque. Verify clearances, system security and band clamp torque after 30-60 miles (50-100 km) of driving.



Figure 9

Congratulations! You are ready to begin experiencing the improved power, sound and driving excitement of your **MBRP** Performance Exhaust system. We know you will enjoy your purchase.